

PRODUCT DATA SHEET

July, 2008

**120 BBL OPEN TOP
(MUD TANK)**

GENERAL INFORMATION

This skid-mounted tank is designed to provide easy viewing of the tank contents. Interior walls are smooth for easy cleanout.

WEIGHTS AND MEASURES

| | | |
|-------------|-------|---|
| » Capacity: | | 120 BBL. (5040 gal.) |
| » Height: | | 6'-5" (overall) 5'-11" (tank only) |
| » Width: | | 8'-0" |
| » Length: | | 17'-6" (tank only) 19'-7" (skid to skid) |
| » Weight: | | 7,000 lbs. (est.) |

STRUCTURAL DESIGN

| | | |
|---------------------------|-------|---|
| » Floor: | | ¼" thick ASTM A36 carbon steel |
| » Sides/Ends: | | ¼" thick ASTM A36 carbon steel (smooth walls on interior side) |
| » Wall Frame: | | 4"x4" tubular steel (on external wall surfaces) |
| » Floor Frame: | | 4"x4" tubular steel (on external floor surface) |
| » Skid Pipe: | | 4x7.7 I-beam or 3x5 tubular steel |
| » Internal Cross Bracing: | | None |

ACCESSORIES

| | | |
|---------------------------|-------|---|
| » Manifold: | | None |
| » Valves: | | Two 6" butterfly valves on each end of tank; approx. 2½ feet from tank C/L to left and right |
| » Cleanout Platform: | | One on each end of tank |
| » Interior Access: | | The tank has an open top |
| » Ladders: | | 2-step access platforms on each end of tank |
| » Drain/Fill Connections: | | Total of four (6"), two on each end of tank |
| » Level Gauge: | | None |

SURFACE DETAILS

| | | |
|---------------------|-------|-------------------------|
| » Exterior Coating: | | High Gloss Polyurethane |
| » Interior Coating: | | None |
| » Placard Mounts: | | None |

TESTS/CERTIFICATIONS

| | | |
|-------------------|-------|--|
| » Test Performed: | | Construction/major repairs – hydrotest Scheduled- Level I, II and III inspections |
|-------------------|-------|--|

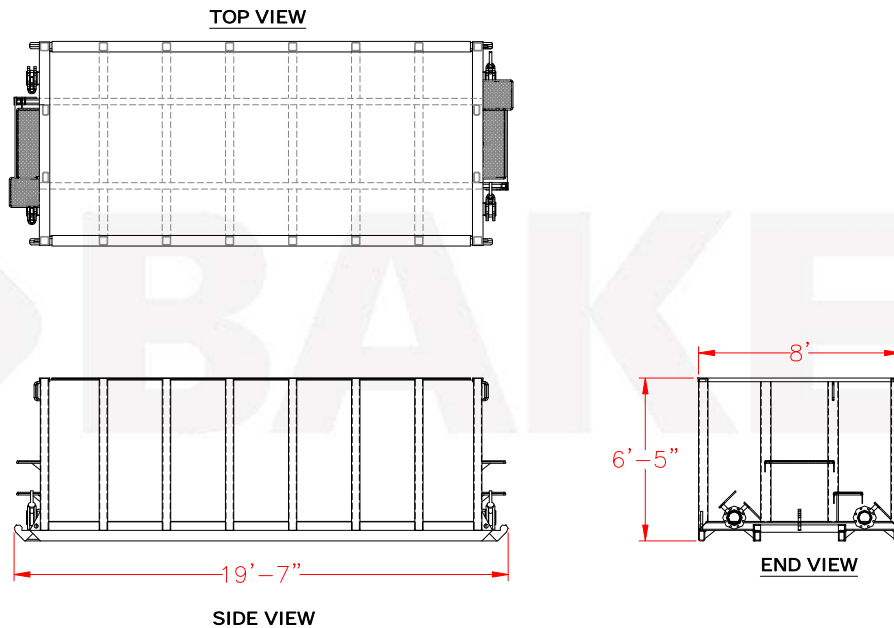

To the best of our knowledge the technical data contained herein are true and accurate at the date of issuance and are subject to change without prior notice. No guarantee of accuracy is given or implied because variations can and do exist. NO WARRANTY OR GUARANTEE OF ANY KIND IS MADE BY BAKERCORP, EITHER EXPRESSED OR IMPLIED.