

PRODUCT DATA SHEET

January, 2007

SAFETY VAPOR TANK

GENERAL INFORMATION

Vapor tight steel tank with two sealed top access hatches and pressure/vacuum relief valve. Some models are equipped with heating coils.

WEIGHTS AND MEASURES

» Capacity: Standard tank – 500 BBL. (21,000 gal.) Short tank – 475 BBL. (19,950 gal.)
» Height: Standard – 12'-6" Short – 11'-10"
» Width : Standard – 8'-0" Short – 8'-0"
» Length: Standard – 35'-0" (37'-6" incl. stairway) Short – 35'-0" (37'-6" incl. stairway)
» Weight: Standard – 21,000 lbs. (approx.) Short – 20,500 lbs. (approx.) (Add 800 lbs. if equipped with heating coils)

STRUCTURAL DESIGN

» Floor: ¼" thick ASTM A36 carbon steel plate
» Sides/Ends: ¼" thick ASTM A36 carbon steel
» Top Deck: ¼" thick ASTM A36 carbon steel
» Wall Frame Structural steel channel/angle on interior
» Floor Frame: 6" carbon steel I-beam on exterior side
» Top Frame: 4" steel channel
» Internal Cross Bracing: 15 – 3"x3"x¼" angle iron

FEATURES

» Valves: May be fitted with a combination of 4" and 6" butterfly valves.
» Relief Valve: 16 oz./in ² pressure setting, 0.4 oz./in ² vacuum setting; Buna-N seal
» Interior Access Hatches: 2-50" long x 32" wide marine-style (rounded ends)
» Access Hatch Seals: 1" x 1¼" neoprene gasket

FEATURES – cont.

» Manways: None
» Roof Piping Connection: 1-4" 150# flanged (blinded) connection, driver side on dolly end
» Total Drain: (1)- 4" pipe and slip-on flange, driver side, tractor end (some tanks have 6")
» Front Collar: Size varies, 2" – 4"
» Bottom Sump: One on each end of tank, either flat bottomed, 12" diameter, 3" deep, or domed, 14" diameter, 4" deep
» Exterior Stairway: Rear end – lower section folds for extension and retraction. Stairway includes handrails.
» Internal Ladder: One, located at rear top hatch opening
» Guardrails: Around the top deck; fold-down.
» Level Gauge: Ball float style, 2-8" 304 SS floats.
» Rear Wheels: Removable dolly (not a fixed axle)

SURFACE DETAILS

» Exterior Coating: High Gloss Polyurethane
» Interior Coating: None
» Safety Paint: Safety yellow on all moveable safety equipment, handrails, stairs etc.

TESTS/CERTIFICATIONS

» Tests Performed: New construction/skin repairs: hydrotest Scheduled: Level I, II & III inspections. NESHAP testing is part of Baker's Level II inspection.
---------------------------	---

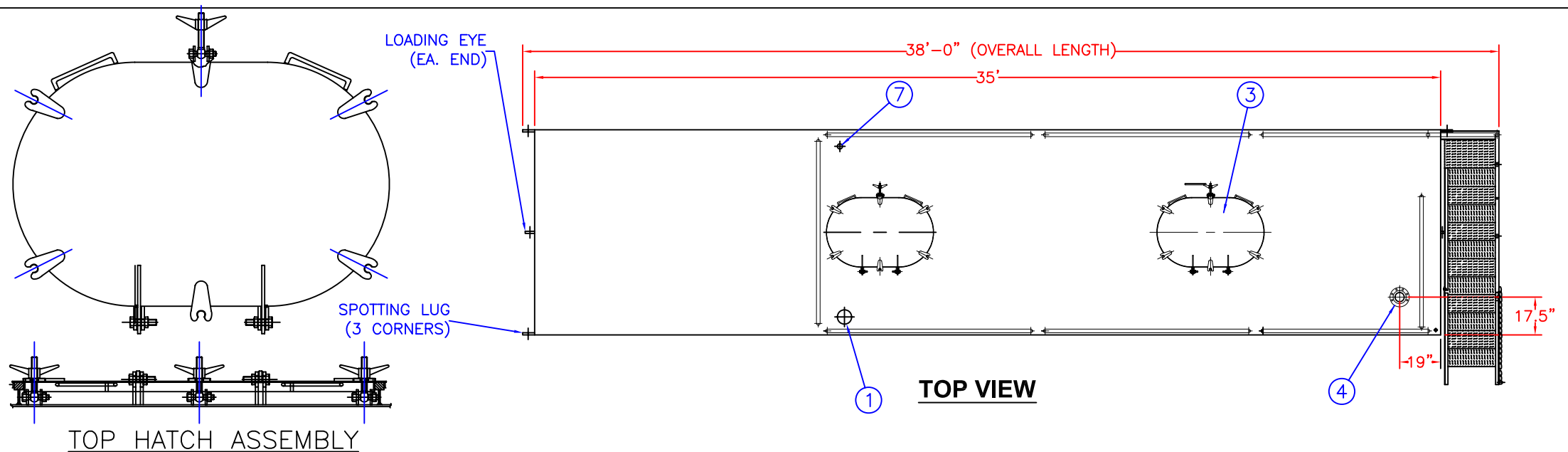

ITEM	QTY	DESCRIPTION
1	1	PRESSURE/VACUUM RELIEF VALVE (SEE NOTE 2)
2	4	4/6" INLET/DRAINS - CAPS/B-FLY VALVE (SEE NOTE 1)
3	2	MARINE STYLE VAPOR PROOF HATCH
4	1	4/6" FLANGE OPG W/BLIND FLG (SEE NOTE 1)
5	1	LEVEL INDICATOR
6	1	OSHA COMPLIANT STAIRWAY & ROOF GUARD RAILS
7	1	2' WELD COLLAR & PLUG
8	1	INTERNAL LADDER
9	2	3" COIL INLET & OUTLET W/BLIND FLG (SEE NOTE 3)

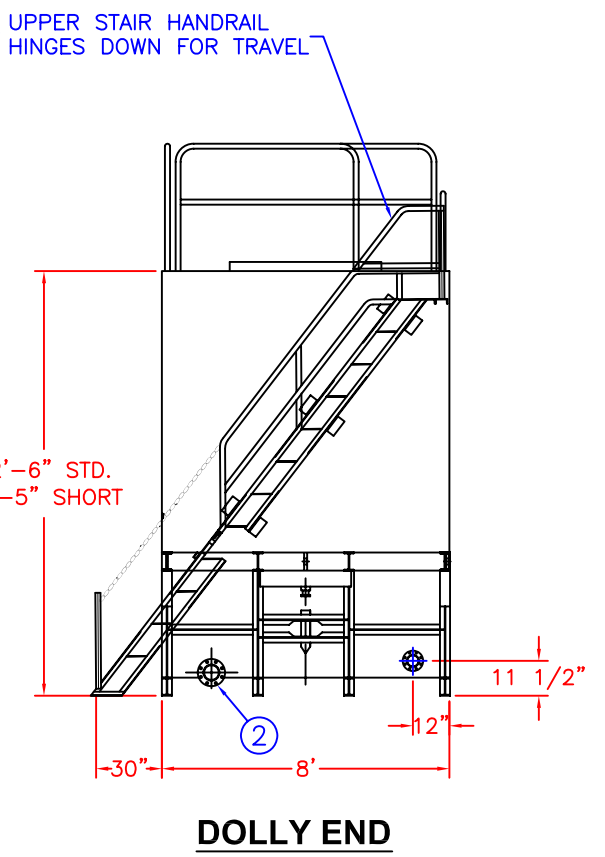
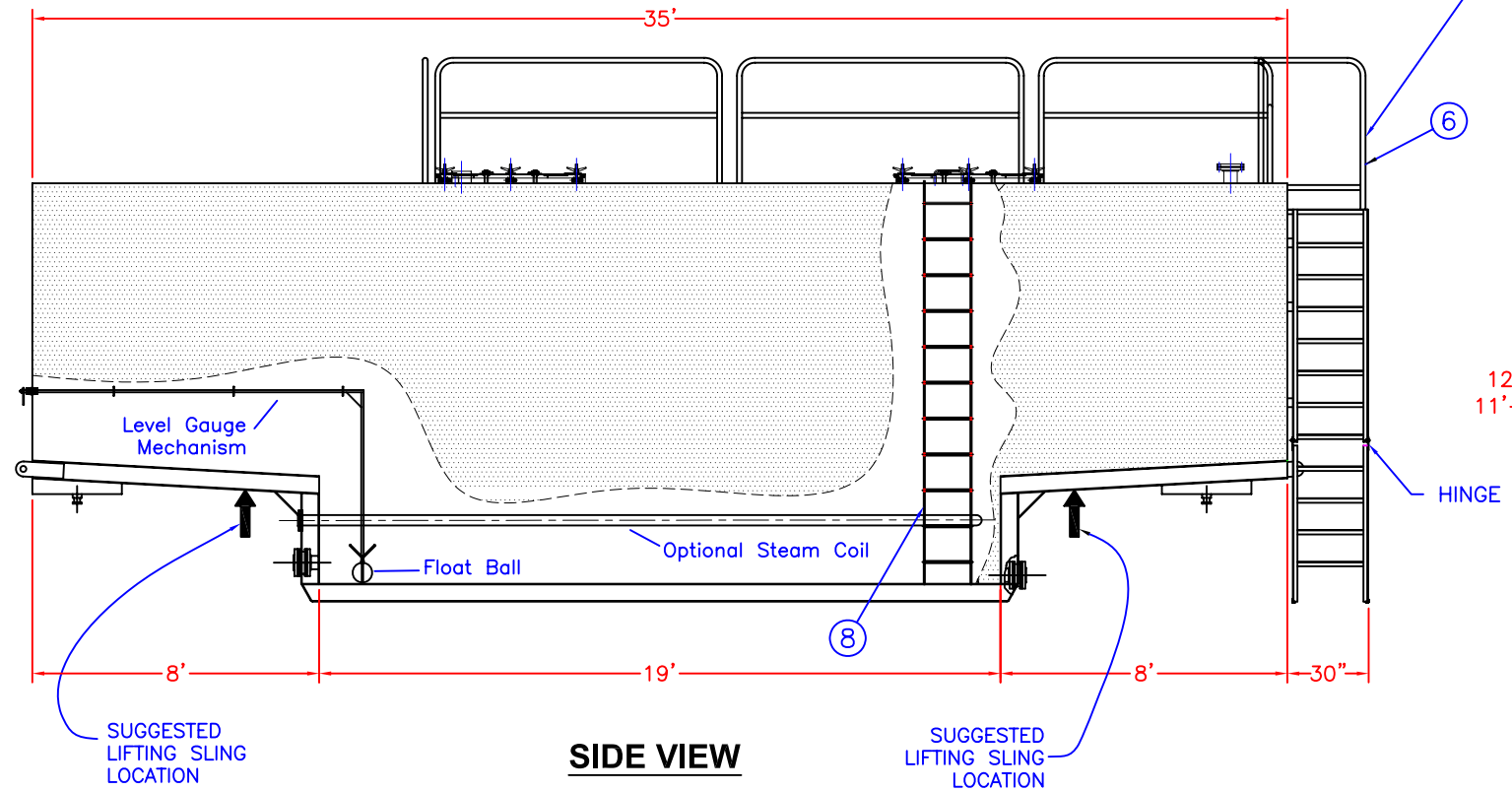
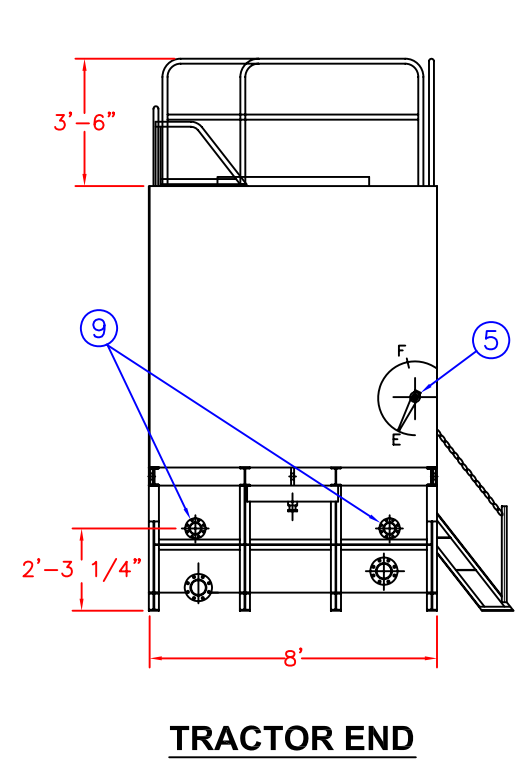

SPECIFICATIONS:

- 1) Tank Capacity
Standard: 21,000 gallons (500 BBL)
Short: 19,950 gallons (475 BBL)
- 2) Tank Weight: 22,000 - 23,000 lbs. (empty)
- 3) Material of Construction: A36 Carbon Steel

NOTES:

- 1. This drawing is a baseline representation for this model of tank. Variations between this drawing and the actual equipment in the field can and do exist, primarily with appurtenance locations, sizes and quantities. Consult your local BakerCorp representative if specific needs exist.
- 2. THESE TANKS ARE NOT DESIGNED FOR TRANSPORTING LIQUIDS. Tanks should be moved only when empty.
- 3. This tank is equipped with a pressure/vacuum relief valve set at 1.0 lbs/sq. in. pressure and 0.4 oz/sq.in. vacuum.
- 4. Some tanks are equipped with heating coils made from carbon steel pipe.

The information contained herein is proprietary to BakerCorp and shall not be reproduced or disclosed in whole or in part, or used for any design or manufacture except when user obtains direct written authorization from BakerCorp.

REV.	DESCRIPTION	DATE	BY
G			
F			
E			
D			
C	ADDED HATCH TO FRONT/LIGHTENED LINEWEIGHT	7/12/05	Z.E.R
B	ADDED COIL, LLG & MODIF. NOTES	18APR05	VAW
A	REDRAWN	18FEB02	A.R.

BAKERCORP™ 3020 OLD RANCH PARKWAY
SEAL BEACH, CA 90740-2751

SCALE: None	SIZE B	ORIGINAL DWG. DATE 18FEB02
DRAWN BY: A. R.	APPROVED BY: -	CAT/CLASS --
TITLE SAFETY VAPOR TANK (SVP)		SHEET 1 OF 1
DRAWING NO. S-1-M0006-1-		REV. C