

PRODUCT DATA SHEET

January, 2007

220 BBL EZ CLEAN OPEN TOP (MUD TANK)

GENERAL INFORMATION

This skid-mounted tank is designed to provide easy viewing of the tank contents. Interior walls are smooth for easy cleanout.

WEIGHTS AND MEASURES

» Capacity:	220 BBL (9240 gal.)
» Height:	6'-4" (overall) 5'-8" (tank only)
» Width :	8'-0"
» Length:	30'-0" (tank only) 33'-0" (skid to skid)
» Weight:	11,450 lbs.

STRUCTURAL DESIGN

» Floor:	¼" thick ASTM A36 carbon steel
» Sides/Ends:	¼" thick ASTM A36 carbon steel (smooth walls on interior side)
» Wall Frame:	4"x4" tubular steel (on external wall surfaces)
» Floor Frame:	4"x4" tubular steel (on external floor surface)
» Skid Pipe:	4x7.7 I-beam or 3x5 tubular steel
» Internal Cross Bracing:	None

ACCESSORIES

» Manifold:	None
» Valves:	One 6" butterfly valve (one end) One 8" butterfly valve (opposite end)
» Cleanout Platform:	One on each end of tank
» Interior Access:	The tank has an open top
» Ladders:	2-step access platforms on each end of tank
» Drain Connection:	Four inch or six inch
» Inlet Connection:	Four inch or six inch
» Level Gauge:	None

SURFACE DETAILS

» Exterior Coating:	High Gloss Polyurethane
» Interior Coating:	None
» Safety Paint:	None
» Placard Mounts:	None

TESTS/CERTIFICATIONS

» Test Performed:	Construction/major repairs – hydrotest Scheduled- Level I, II and III inspections
-------------------	-------	--------------------------------------------------------------------------------------

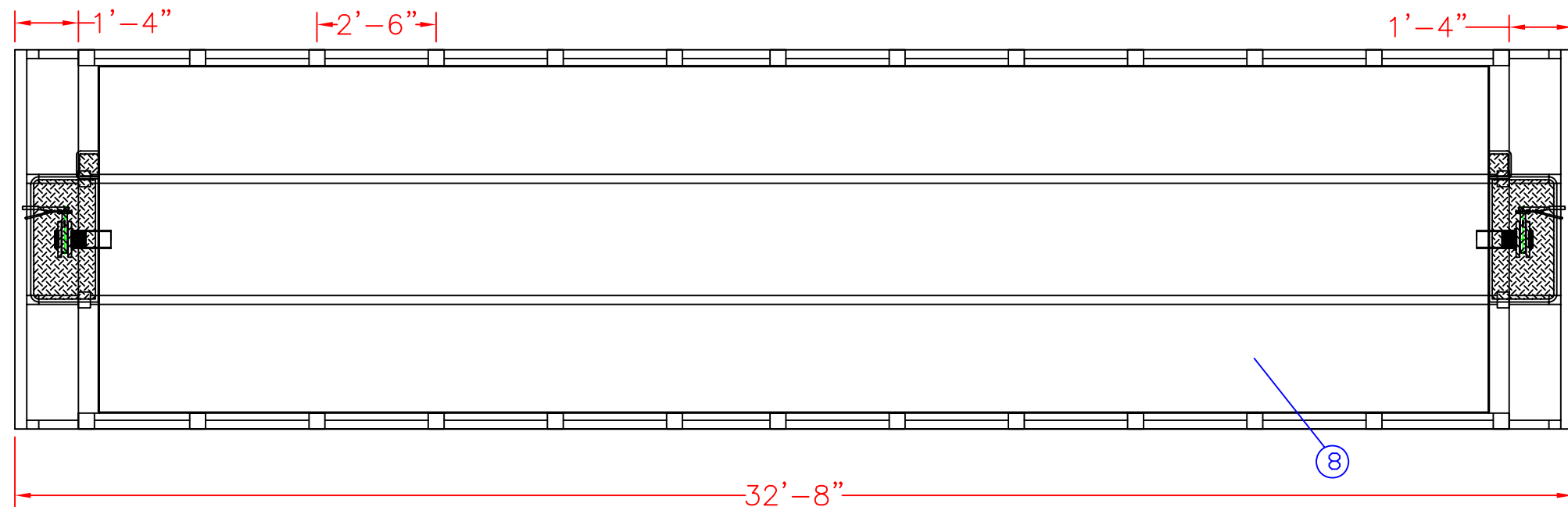

ITEM NO.	QTY.	PART NO.	
1	13	--	FRAME SUPPORT ASSEMBLY, SQUARE TUBING 4x4x1/4"
2	4	--	FRONT&BACK PANEL SUPP., RECTANG. TUBING, 5x3x3/8"
3	2	--	SIDE PANEL SUPP., STRUCTURAL L ANGLE, 5x3x1/4" THK.
4	2	--	FRONT & BACK TOP SUPP., STRUCT. CHANNEL, 5x3x3/8" THK.
5	2	--	FLOOR SUPPORTS
6	2	--	OUTER SKID ASSEMBLY
7	1	--	BUMPER ASSEMBLY
8	1	--	FLOOR PANEL, STEEL 1/4" THK.
9	2	--	SIDE PANEL, STEEL 1/4" THK.
10	2	--	FRONT & BACK PANEL, STEEL 1/4" THK.
11	4	--	STEPS
12	2	--	TOTAL DRAIN ASSEMBLY

THIS IS AN OPEN TOP TANK

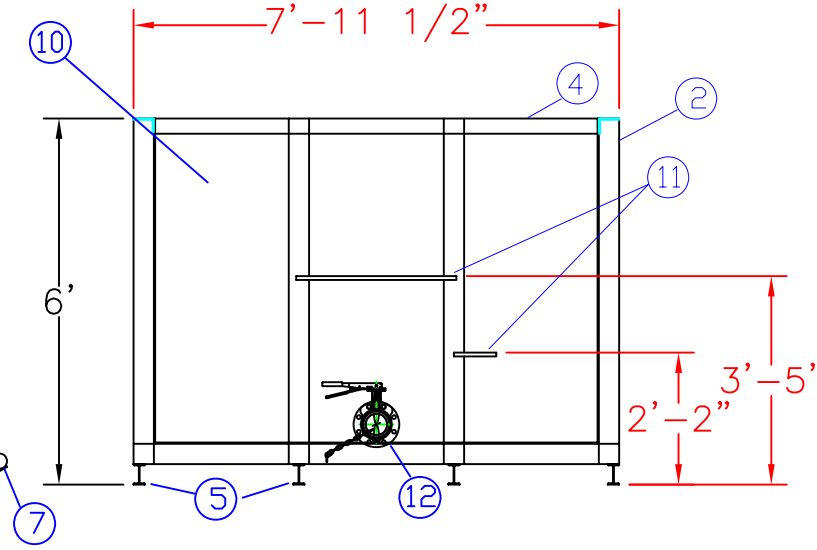
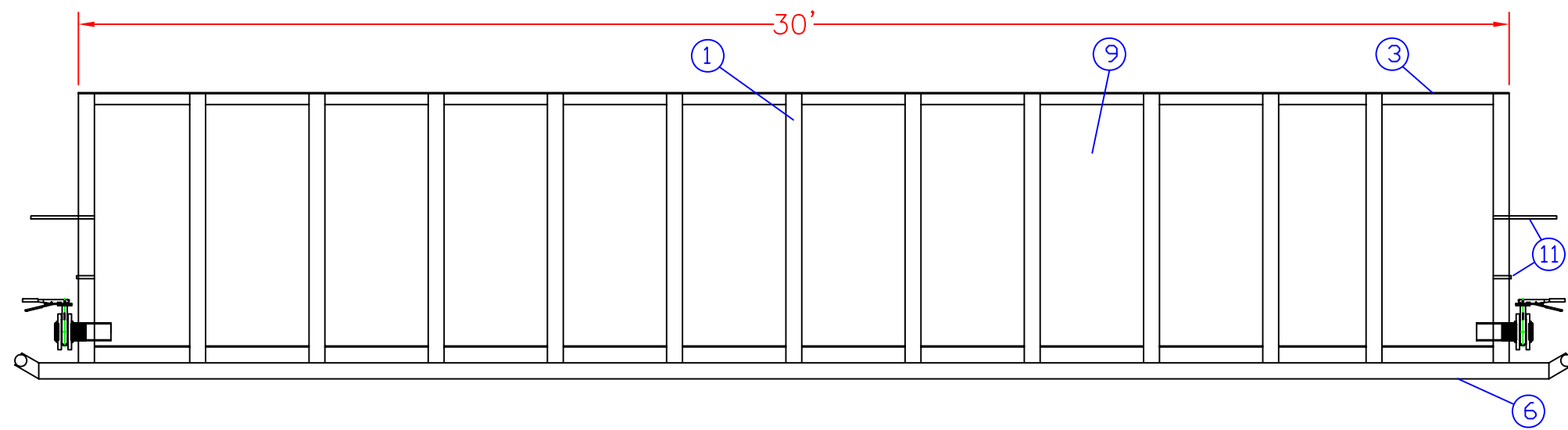

SPECIFICATIONS:

- 1) Tank Capacity: 9,240 gallons (220 BBL)
- 2) Tank Weight: 11,450 lbs. (empty)

NOTES:

- 1. This drawing is a baseline representation for this model of tank. Variations between this drawing and the actual equipment in the field can and do exist, primarily with appurtenance locations, sizes and quantities. Consult your local BakerCorp representative if specific needs exist.
- 2. This tank is to be transported while empty only. It is not designed to transport loads.

<p>The information contained herein is proprietary to BakerCorp and shall not be reproduced or disclosed in whole or in part, or used for any design or manufacture except when user obtains direct written authorization from BakerCorp.</p>				3020 OLD RANCH PARKWAY SEAL BEACH, CA 90740-2751		
G				SCALE:	SIZE	ORIGINAL DWG. DATE
F				Do Not Scale	B	05APR02
E				DRAWN BY:	APPROVED BY:	CAT/CLASS
D				A. R.	-	--
C				TITLE		SHEET
B				220 BBL MUD TANK		1 OF 1
A				DRAWING NO.		REV.
REV.	DESCRIPTION	DATE	BY	S-1-M0008-1-		0