

PRODUCT DATA SHEET

January, 2007

MAYFAB INTERMODAL

GENERAL INFORMATION

This container is not to be used for free liquid storage.

WEIGHTS AND MEASURES

» Capacity:	25 yd ³
» Height:	6'-4"
» Width :	8'-0"
» Length:	19'-10½"
» Tare Weight:	6080 lbs.
» Actual Vol:	664 cu. ft.
» Load Limit:	46,820 lbs.

STRUCTURAL DESIGN

» Floor:	7-gauge, one piece carbon steel
» Side Plate:	10-gauge, one piece, lower longitudinal edges radius formed inward
» Front Plate:	10-gauge, one piece
» Door Sheet:	10-gauge, one piece
» Bottom Rails:	6"x2"x¼" structural tubing
» Corners:	Standard ISO corner fittings

FEATURES

» Lid Options:	Roll-tarp
» Tarp:	18 oz. Nylon reinforced canvas
» Tarp Bows:	1"x1"x16" gauge structural tubing

FEATURES - con't

» Roll Pipe:	1 ½" schedule 5 galvanized pipe
» Crank Tube:	1.08" O.D. galvanized pipe
» Wheels:	Retractable, 8" dia. x 7" long, at front and rear
» Fork Pockets:	12"x6"x¼" plate formed channels
» Door Latch:	Three independent ratchet binders and chains
» Door Gasket:	One piece EPDM extrusion with 12-gauge retainer clips
» Placard Mounts:	(4) aluminum holders riveted to 10-gauge sheets supported by 1x1x1/8 angle stand-offs
» Splashguard:	10-gauge formed panels, both ends

SURFACE DETAILS

» Exterior Coating:	High Gloss Polyurethane
» Interior Lining:	Polyliners only, no coating

TESTS/CERTIFICATIONS

» Tests Performed:	Per AAR at manufacturer Baker Level inspections performed per QMS schedule.
» Certification:	AARM930-90

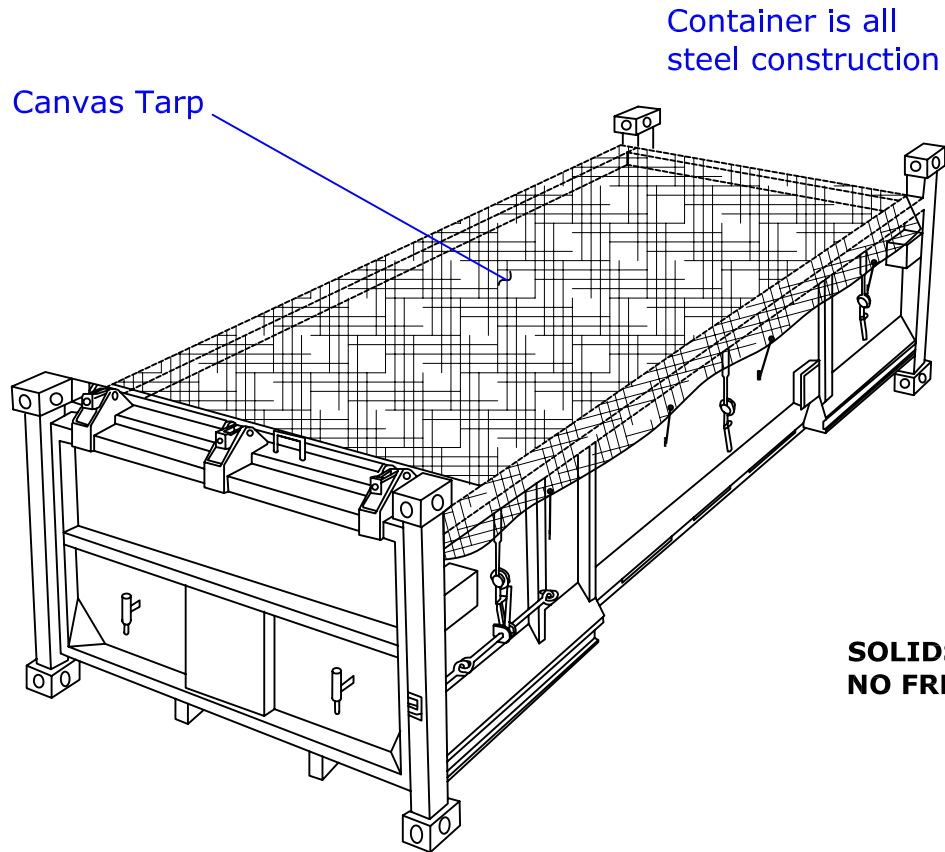

SPECIFICATIONS:

- 1) Capacity: 25 cubic yards
- 2) Height: 6'-4"
- 3) Width: 8'-0"
- 4) Length: 19'-11"

**SOLIDS CONTAINMENT ONLY -
NO FREE LIQUIDS**

NOTES:

- 1. This drawing is a general representation for this class of equipment. Refer to the Product Data Sheet for more detailed information.

The Information contained herein is proprietary to BakerCorp and shall not be reproduced or disclosed in whole or in part, or used for any design or manufacture except when user obtains direct written authorization from BakerCorp.				 3020 OLD RANCH PARKWAY SEAL BEACH, CA 90740-2751		
G				SCALE: N.T.S.	SIZE: A	ORIGINAL DWG. DATE: 24JAN06
F				DRAWN BY: P.J.B.	APPROVED BY: -	CAT/CLASS: NA
E				TITLE: MAYFAB INTERMODAL		SHEET: 1 OF 1
D				DRAWING NO. S-6-M0004-1-		REV. 0
C						
B						
A						
REV.	DESCRIPTION	DATE	BY			