

PRODUCT DATA SHEET

January, 2007

GALBREATH INTERMODAL

GENERAL INFORMATION

This container is not to be used for free liquid storage.

WEIGHTS AND MEASURES

» Capacity:	25 yd ³ & 30 yd ³
» Height:	25 yd ³ : 6'-6" 30 yd ³ : 7'-7½"
» Width :	Both capacities: 8'-0"
» Length:	Both capacities: 19'-10½"
» Weight:	25 yd ³ RT - 7859 lbs. 30 yd ³ RT - 9680 lbs.
» Inside Dimensions:	Both capacities: 82" x 18'-11½"

STRUCTURAL DESIGN

» Floor:	7-gauge steel plate
» Walls:	12-gauge steel plate
» Door/Header:	7-gauge steel plate, hinged on street side
» Bulkhead:	7-gauge steel plate
» Corners:	Eight standard ISO corner castings
» Truck Rails:	36½" apart

FEATURES

» Lid Options:	Roll-tarp only
» Liner Hooks:	Spaced on 30" centers
» Tarp Hooks:	Nine on each side wall
» Wheels:	Four total
» Nose Rollers:	Front & rear, 6-5/8" x 10"
» Splashplates:	One located on bulkhead end
» Forklift Pockets:	Yes
» Gaskets:	Door- pure neoprene SCE44/45
» Door Locks:	Latch mechanism
» Door Hinges:	Street side

SURFACE DETAILS

» Exterior Coating:	High Gloss Polyurethane
» Interior Lining:	Polyliners only, no coating
» Placard Mounts:	Four, one on both sides and both ends

TESTS/CERTIFICATIONS

» Tests Performed:	Water test after manufacture. Level I, II and III inspections thereafter.
» Certification:	AARM930-90

WEIGHTS AND MEASURES

➤ Capacity:	25 yd ³ & 30 yd ³
➤ Height:	25 yd ³ : 6'-6" 30 yd ³ : 7'-7½"
➤ Width:	Both capacities: 8'-0"
➤ Length:	Both capacities: 19'-10½"
➤ Weight:	25 yd ³ RT - 7859 lbs. 30 yd ³ RT - 9680 lbs.
➤ Inside Dimensions:	Both capacities: 82" x 18'-11½"

Container is all steel construction

Canvas Tarp

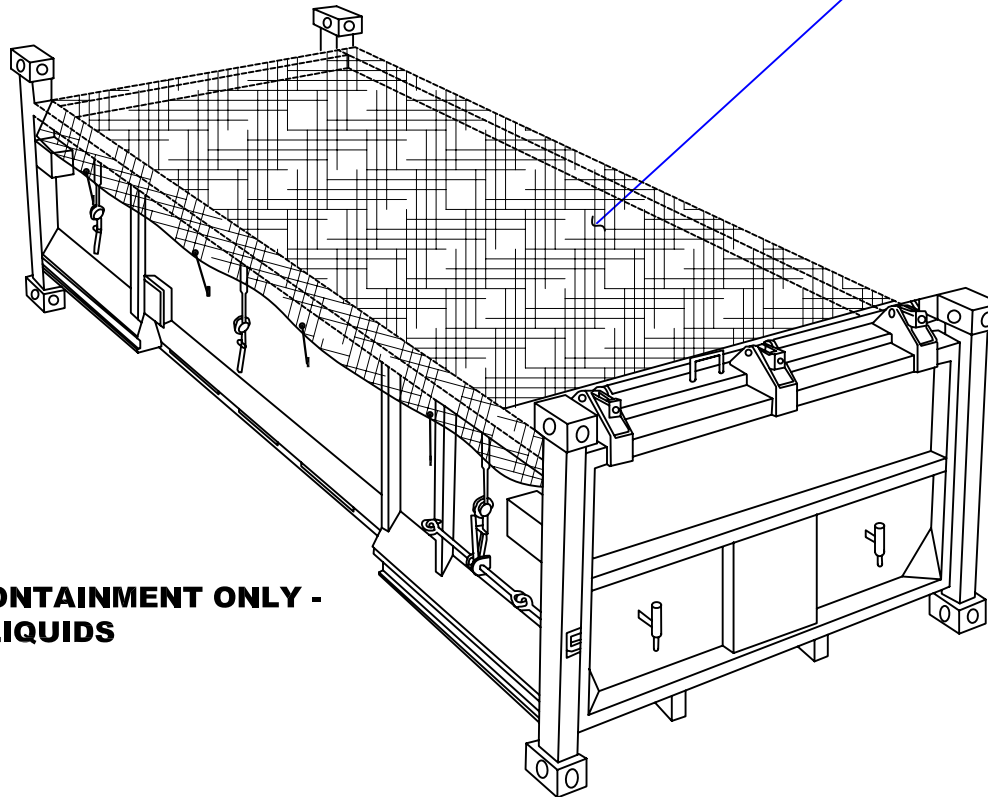

**SOLIDS CONTAINMENT ONLY -
NO FREE LIQUIDS**

NOTES:

1. This drawing is a general representation for this class of equipment. Refer to the Product Data Sheet for more detailed information.

The Information contained herein is proprietary to BakerCorp and shall not be reproduced or disclosed in whole or in part, or used for any design or manufacture except when user obtains direct written authorization from BakerCorp.				 3020 OLD RANCH PARKWAY SEAL BEACH, CA 90740-2751					
G				SCALE:	N.T.S.	SIZE:	A	ORIGINAL DWG. DATE:	26JAN06
F				DRAWN BY:	P.J.B.	APPROVED BY:	-	CAT/CLASS:	NA
E				TITLE:	GALBREATH INTERMODAL			SHEET:	1 OF 1
D				DRAWING NO.:	S-6-M0007-1-			REV.:	0
C				REV.	DESCRIPTION	DATE	BY		