

## PRODUCT DATA SHEET

January, 2007

## ACCURATE INTERMODAL

### GENERAL INFORMATION

This container is not to be used for free liquid storage.

### WEIGHTS AND MEASURES

» Capacity:	25 yd <sup>3</sup>
» Height:	6'-6"
» Width :	8'-0"
» Length:	19'-10½"
» Weight:	Roll Tarp - 6415 lbs.; Metal Lid - 7615 lbs.

### STRUCTURAL DESIGN

» Floor:	7-gauge steel plate
» Walls:	10-gauge steel plate
» Side Supports:	10-gauge steel, 3" deep x 10" wide
» Side Sills:	6" formed 10-gauge channel
» Floor Frame:	5" formed 10-gauge channel on 16" ctr's
» Door/Header:	Two horizontal and two vertical ¼" plate-formed channel frames, plus two 7-gauge vertical members. Door plate is 10-gauge steel. Three hinges at top. Hinge pins are stainless steel.
» Bulkhead:	10-gauge sheet steel with two vertical 2"x4"x¼" structural tubes welded to bulkhead sheet. Top horizontal tube 4"x4"x7 gauge min., A500, Grade B welded structural tube.
» Corners:	Eight standard ISO corner castings
» Truck Rails:	6"x2"x¼" structural tubing

### FEATURES

» Lid Options:	Open top, roll-tarp, metal lid (over/under)
» Liner Hooks:	"J" hooks
» Tarp Hooks:	(Tarped boxes only) Seven on each side of box. Three tarp straps on door.
» Wheels:	Four wheels 7¼" wide x 8½" dia. with swing-up/retractable locking mechanism
» Splashplates:	10-gauge steel plate on each end of container allowing 194" clear opening.
» Forklift Pockets:	81" centers, 14" wide min. and 4½" high min.
» Gaskets:	Door- pure neoprene SCE44/45 Lid- ISOLOSS LS-1525 & LS-1550
» Door Locks:	1-ratchet binder with chains each side 1-ratchet binder under floor with three grab hands on bottom of door.

### SURFACE DETAILS

» Exterior Coating:	High Gloss Polyurethane
» Interior Lining:	Polyliners only, no coating
» Placard Mounts:	Four, one on both sides and both ends

### TESTS/CERTIFICATIONS

» Tests Performed:	<ul style="list-style-type: none"> <li>Water test after manufacture. Level I, II and III inspections thereafter.</li> <li>Top and bottom castings and corner post assembly hydraulically stress tested to three times rated capacity.</li> </ul>
» Certification:	AARM930-90

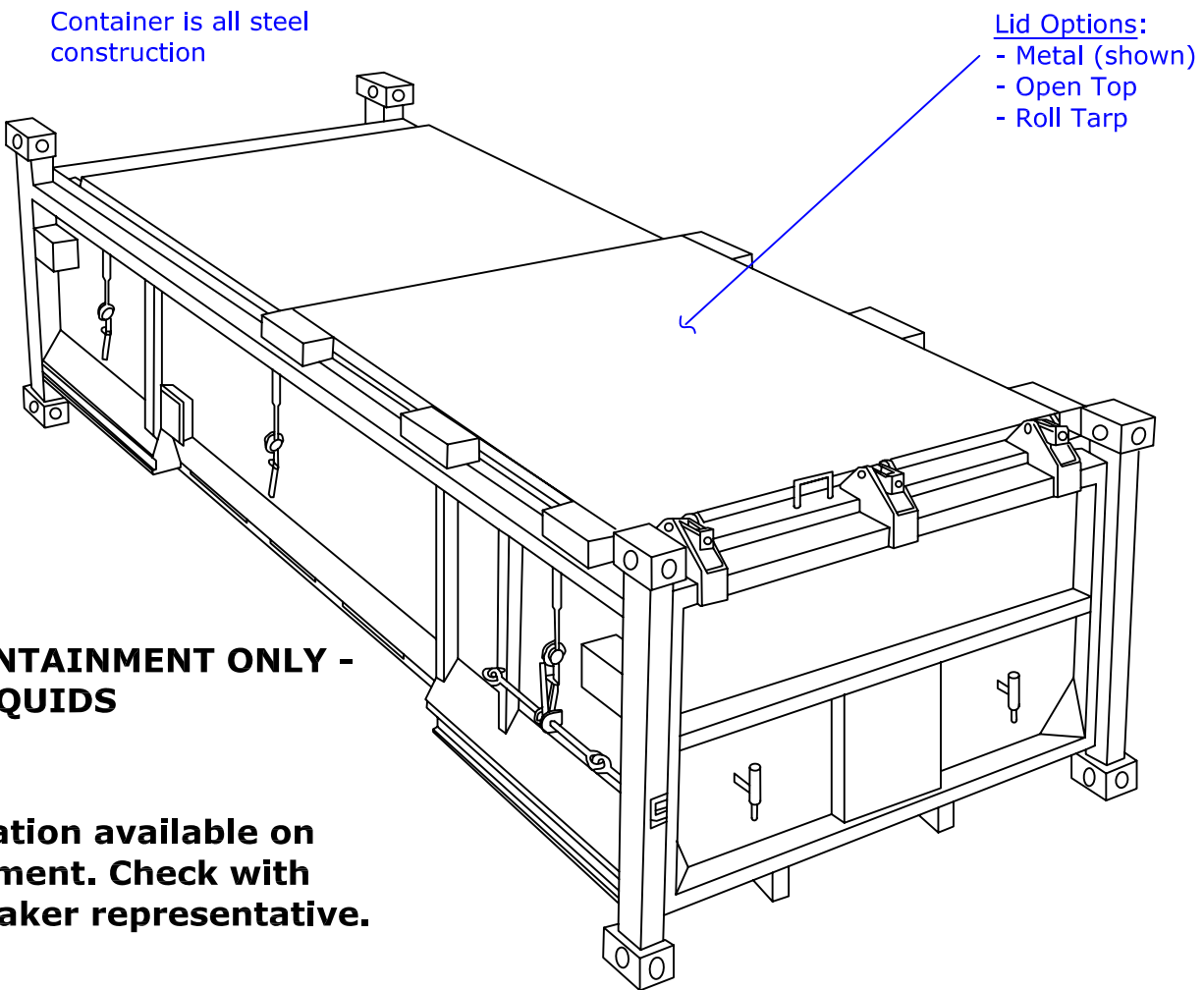

Container is all steel construction

- Lid Options:**
- Metal (shown)
  - Open Top
  - Roll Tarp

Capacity: 25 cu. yds.  
 Height: 6'6"  
 Width: 8'-0"  
 Length: 19'-10"

**SOLIDS CONTAINMENT ONLY -  
 NO FREE LIQUIDS**

**CSC certification available on  
 some equipment. Check with  
 your local Baker representative.**

**NOTES:**

1. This drawing is a general representation for this class of equipment.  
 Refer to the Product Data Sheet for more detailed information.

The Information contained herein is proprietary to BakerCorp and shall not be reproduced or disclosed in whole or in part, or used for any design or manufacture except when user obtains direct written authorization from BakerCorp.				<b>BAKERCORP</b> 3020 OLD RANCH PARKWAY SEAL BEACH, CA 90740-2751	
G				SCALE: N.T.S.	SIZE: A
F				DRAWN BY: P.J.B.	APPROVED BY: -
E					ORIGINAL DWG. DATE: 23JAN06
D					CAT/CLASS: NA
C				TITLE: ACCURATE INDUSTRIES INTERMODAL	
B				SHEET: 1 OF 1	
A				DRAWING NO. S-6-M0001-1-	
REV.	DESCRIPTION	DATE	BY	REV. 0	