

PRODUCT DATA SHEET

January, 2007

6500 GALLON POLY TANK (Original Style and Total Drain)

GENERAL INFORMATION

This type of tank is not to be used for food applications. Potable water applications are generally not acceptable and must be reviewed by the Corporate office first for approval.

WEIGHTS AND MEASURES

» Capacity:	– 6500 gallons (nominal)
» Height [‡] :	– 10'-6" (to top tangent line) 11'-11" (to top of dome) 12'-4" (to highest point on top lid)
» Diameter:	– 10'-0" (nominal)
» Weight*:	– Tank: 1700 lbs. – 1975 lbs. Pad: 400 lbs. - 450 lbs.

*Varies with origin of manufacture

‡ Does not include height of pad. Add four inches for pad thickness to determine heights from grade when pad is used.

DESIGN PARAMETERS

» Tank Material:	– High Density Polyethylene
» Design Pressure:	– 0 psi – vented to atmosphere
» Design Vacuum:	– 0 psi – vented to atmosphere
» Spec. Gravity Limit:	– Original Style – 1.65 Total Drain – 1.9
» Temp. Limit:	– 150° F
» Certification:	– ASTM D1998 (not UL listed)

RESTRICTIONS

» Sulfuric Acid Storage:	–	<ul style="list-style-type: none"> • 80% concentration maximum • Use only tanks with equipment numbers \geq 7376 • Previously repaired tank cannot be used (equipment number should have "W" at end) • 100° F maximum temperature • Top fill only • Top manway must be open during pneumatic filling of tank • Use flexible plumbing fixtures resistant to sulfuric acid
--------------------------	---	--

FEATURES

» Top Vent:	– 2" PVC U-vent (two threaded street elbows)
» Manway:	– Top mounted with 24" opening (34 inch diameter screw-on cover)
» Valves:	– 3" butterfly valve with PVC body and disc, Viton O-Ring seal and 316 SS stem.
» Ladder:	– Top mounted bracket for ladder hook-up. Ladder is not permanently mounted to tank.
» Piping Connections:	– Inlet – 3" with butterfly valve Outlet – 3" with butterfly valve Top – 4" PVC adapter and PVC cap

MISCELLANEOUS

» Options:	– Secondary containment berm
------------	------------------------------

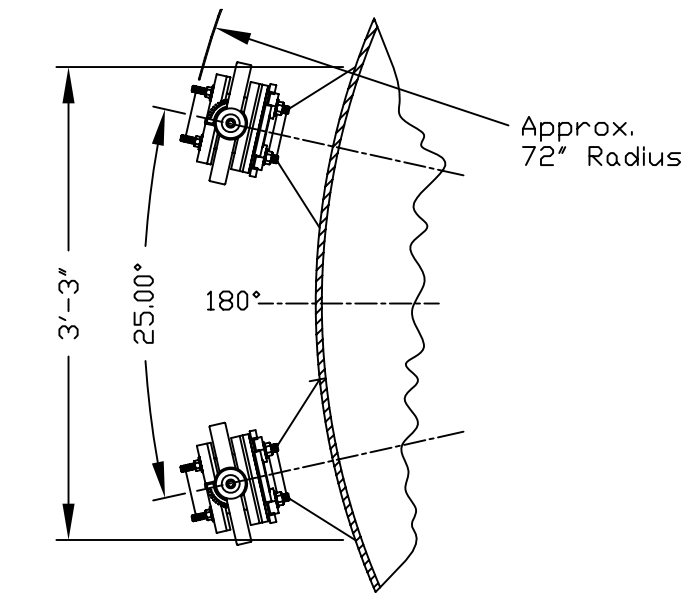
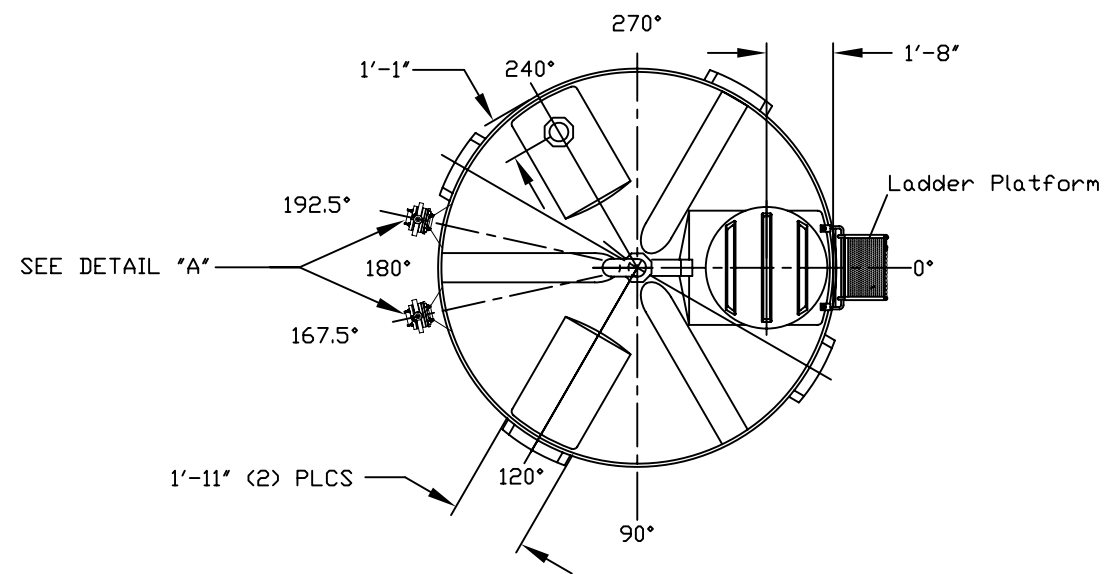

DETAIL "A"
(VALVE LAYOUT & CLEARANCE)
SCALE: NONE

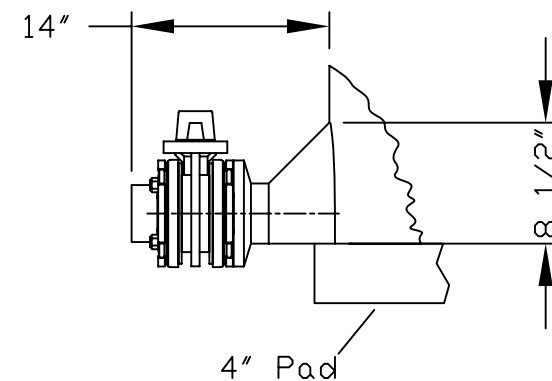
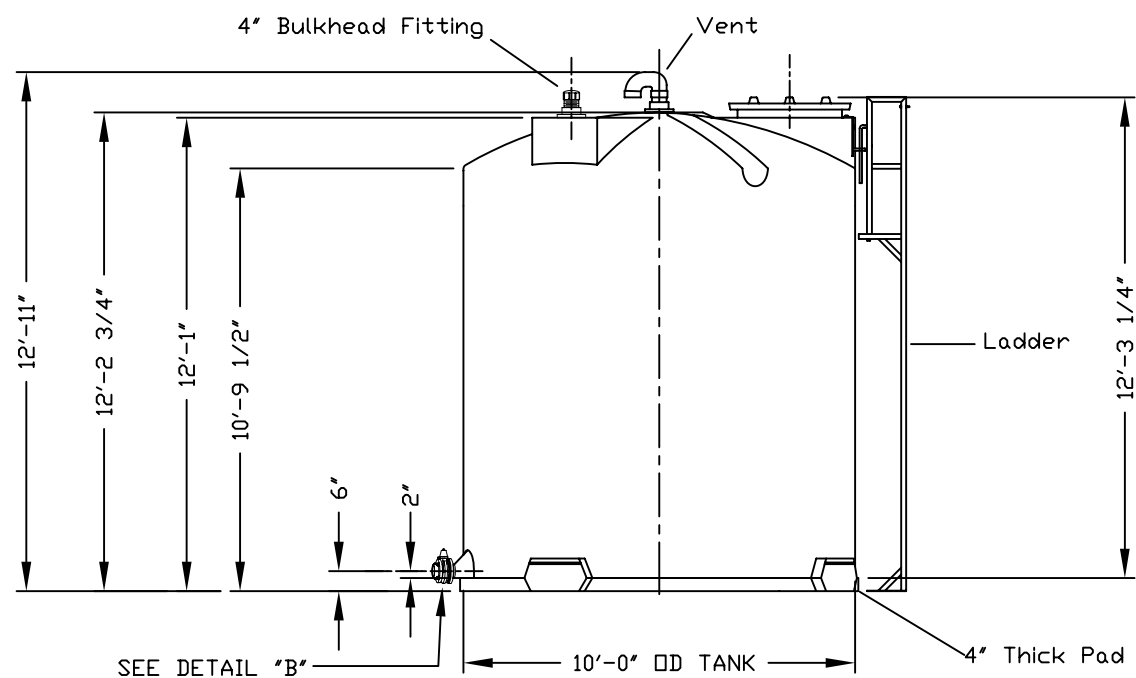

DETAIL "B"
INTEGRALLY MOLDED FLANGED OUTLET (IMFO)
SCALE: NONE

SULFURIC ACID RESTRICTIONS

1. Do not store sulfuric acid above 80% concentration. For concentrations equal to or less than 80%, use tanks with equipment numbers equal to or greater than P7376. Do not use tanks with lower equipment numbers for sulfuric acid. Concentrations greater than 80% require Corporate approval.
2. Sulfuric acid must be less than 100 degrees to be stored in this tank.
3. Sulfuric acid must be filled through the top of the tank only.
4. Tank vent must always be open when storing sulfuric acid.

NOTES:

1. THIS IS A COMPUTER GENERATED DRAWING. DO NOT REVISE BY HAND.
2. DIMENSIONS WILL VARY ±3% DUE TO VARIATIONS IN MULTIPLE MOLDS & CONDITIONS PREVALENT DURING MANUFACTURE & USAGE.
3. DESIGN TANK WALL THICKNESS 1.9 SpG PRODUCT.
4. SEE DRAWING "BK65HUF", TITLED "BAKER 6500 GALLON STORAGE TANK TYPICAL FITTING INSTALLATION", FOR FITTING LOCATIONS.

SPECIFICATIONS:

- 1) Tank Weight: 1650 lbs.
- 2) Pad Weight: 450 lbs.
- 3) Tank Material: HDPE
- 4) Design Pressure: 0 psig
- 5) Vacuum Rating: Atmospheric only
- 6) Temperature limit: 150°F
- 7) Specific Gravity limit: Original Style - 1.65; Total Drain - 1.90

NOTES:

1. This drawing is a baseline representation for this model of tank. Variations between this drawing and the actual equipment in the field can and do exist, primarily with appurtenance locations, sizes and quantities. Consult your local BakerCorp representative if specific needs exist.
2. THIS TANK IS NOT DESIGNED FOR TRANSPORTING LIQUIDS. It should be moved only when empty..

The information contained herein is proprietary to BakerCorp and shall not be reproduced or disclosed in whole or in part, or used for any design or manufacture except when user obtains direct written authorization from BakerCorp.				 3020 OLD RANCH PARKWAY SEAL BEACH, CA 90740-2751	
G				SCALE: Do Not Scale	SIZE B
F					ORIGINAL DWG. DATE 05SEP02
E				DRAWN BY: P.J.B.	APPROVED BY: -
D	Revised dimensions	10/9/06	PJB		CAT/CLASS --
C	Added ladder & add'l dimensions	6/2/06	PJB	TITLE 6500 GALLON POLY TANK	SHEET 1 OF 1
B	Fixed lineweights	7/12/05	Z.E.R		
A	Added pad, valves, vent & bulkhead fitting.	3/10/05	PJB	DRAWING NO. S-3-M0002-1-	REV. D
REV.	DESCRIPTION	DATE	BY		