

PRODUCT DATA SHEET

October, 2008

8-CARTRIDGE FILTER UNIT

GENERAL INFORMATION

This filter provides unsurpassed performance because it separates dense solids prior to cartridge filtration due to the tangential entry, has increased dirt holding capacity and reduced maintenance costs. Components include outer chamber for particle separation, inner chamber for cartridge filtration and built-in drain for purge, if required.

WEIGHTS AND MEASURES

» Capacity:	840 gpm normal; 1200 gpm maximum
» Pressure Rating:	200 psig maximum
» Design Temp:	Up to 140°F
» Height:	7'-0" (Bottom of feet to top of lid handwheel) [Note: 104-1/2" is the cartridge element service height requirement]
» Vessel Diameter:	2'-11 1/2"
» Bolt Circle (feet):	43" diameter
» Weight:	1,600 lbs. dry 3,535 lbs wet (full of water)
» Floor Load:	Approx. 22 psi at feet (wet condition)
» Vessel Volume:	232 gallons

FILTER DESIGN

» Filter Housing	304 Stainless steel (ASTM A-240)
» Cartridge Access:	Swing bolt (28) housing closure
» Closure Gasket:	EPDM O-ring
» Inlet & Outlet:	Six-inch 150# flanges
» Cartridges:	Pleated polyester; 30-3/4" long x 7-3/4" o.d.; eight total required; 1360 ft ² of media surface. Allowable pH range is 3 - 11. (Micron ratings of 0.35 - 150 available)
» Top Vent:	1/2" female NPT coupling; class 1000
» Drain Connections	One bottom and one side wall, 1-1/2" female couplings; class 1000
» Gage Ports:	1/4" female NPT class 1000 couplings on inlet and outlet nozzles,

SURFACE DETAILS

» Exterior Surface:	Electro-polish finish
---------------------	-----------------------

TESTS / CERTIFICATIONS

» Tests Performed:	Scheduled QMS inspections
--------------------	---------------------------

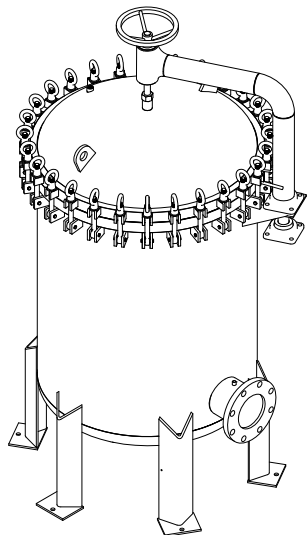

Note: This unit may be provided on a skid-mount

Estimated Clean Water Pressure Drop

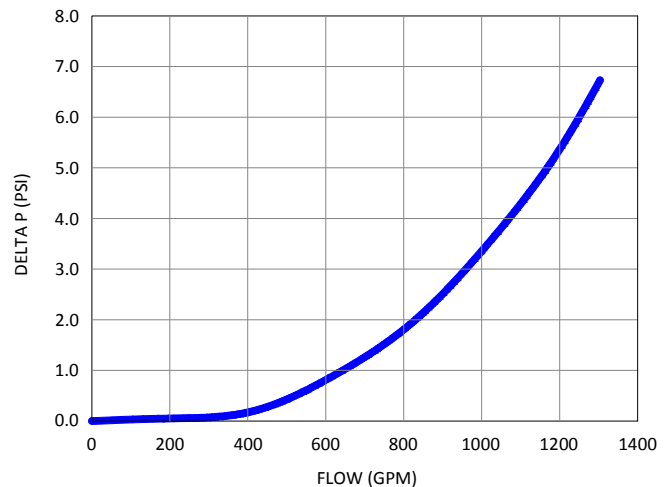

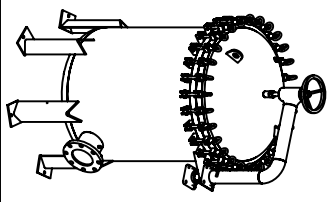
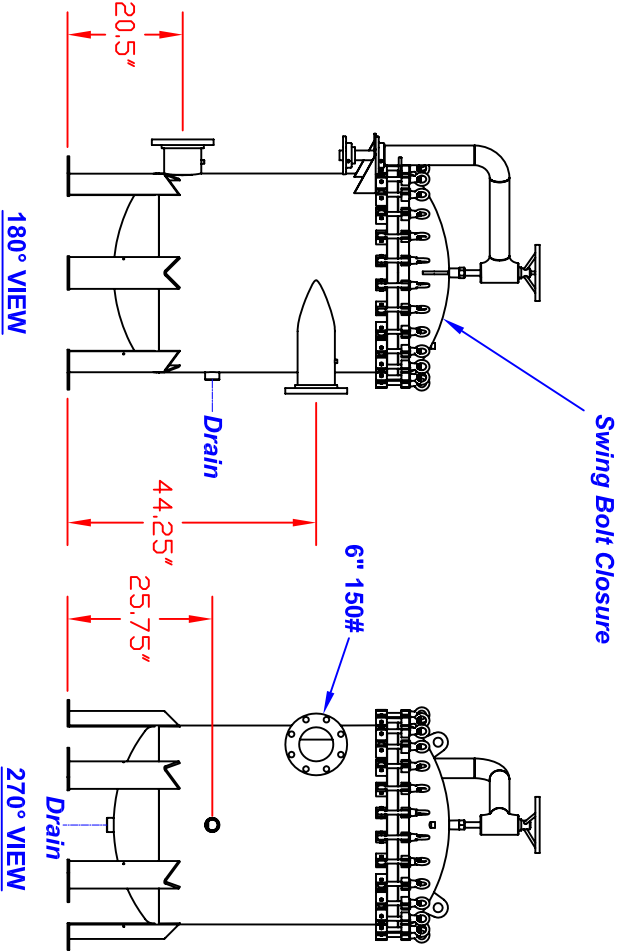
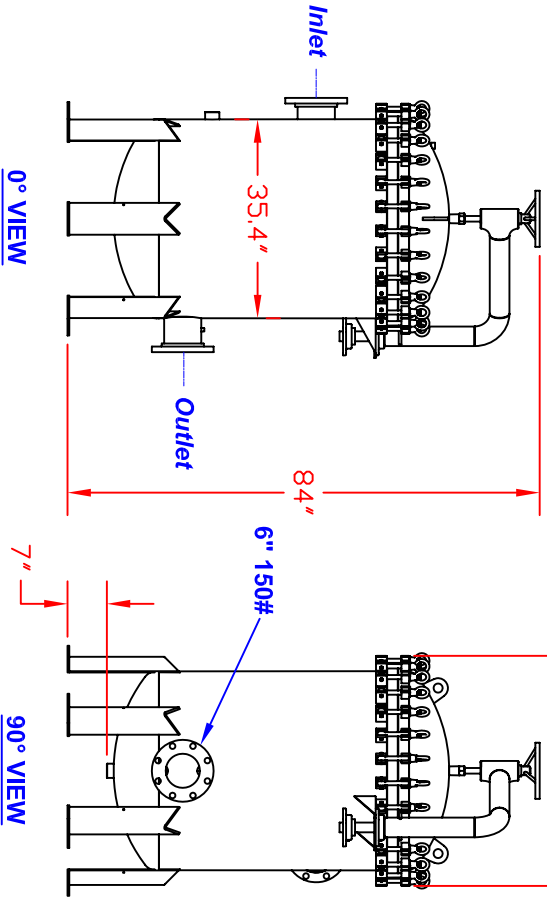
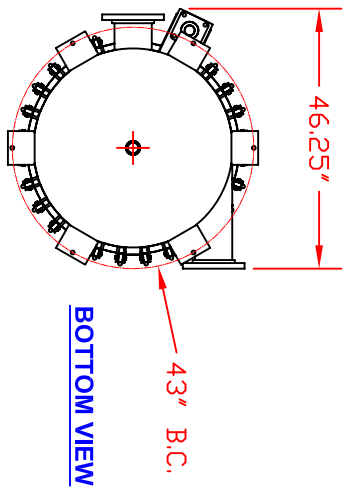
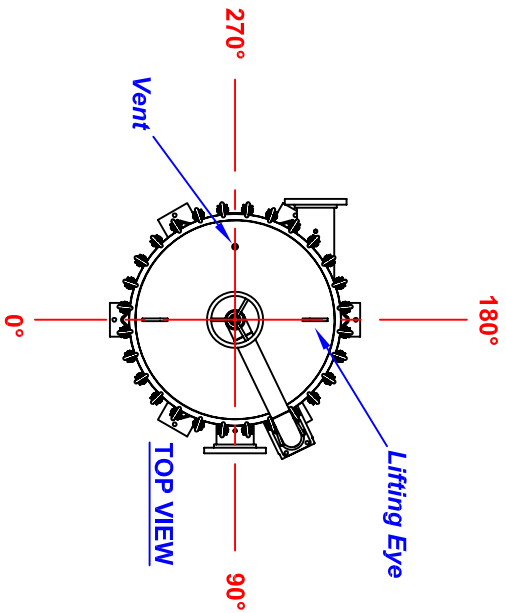

NOTES:

1. Vessel is constructed of 304 stainless steel.
2. Normal capacity up to 840 gpm; 1200 gpm maximum.
3. Pressure rating is 200 psig
4. Design temperature is 140 degrees
5. Weight: 1600 lbs dry; 3535 lbs. full of water

<p>The information contained herein is proprietary to Baker Tanks and shall not be reproduced or disclosed in whole or in part, or used for any design or manufacture except when user obtains direct written authorization from Baker Tanks.</p>		<p>3020 OLD RANCH PARKWAY SEAL BEACH, CA 90740-2751</p>	
G	SCALE:	SIZE:	ORIGINAL DWG. DATE:
F	DRAWN BY:	A	09OCT08
E	P.J.B.	APPROVED BY:	CNT/GLASS
D			NA
C	TITLE:		SHEET
B	8-CARTRIDGE FILTER UNIT		1 OF 1
A	DRAWING NO.:		REV.
REV.	DESCRIPTION	DATE	BY
	S-9-M0026-1-		0