

ITEM	QTY	DESCRIPTION
1	391'	4" SCH. 40 CARBON STEEL PIPE (GEL LINE)
2	5	4"-150# BUTTERFLY VALVE
3	4	21" MANWAY
4	1	BALL FLOAT LEVEL GAUGE MECHANISM
5	4	8" BLAYLOCK MODEL LL10 PRESSURE/VACUUM GAUGE
6	1	4" SCH. 40 45 DEG. ELBOW
7	1	4" SCH. 40 WELD TEE
8	1	4"X3" SCH. 40 WELD REDUCER

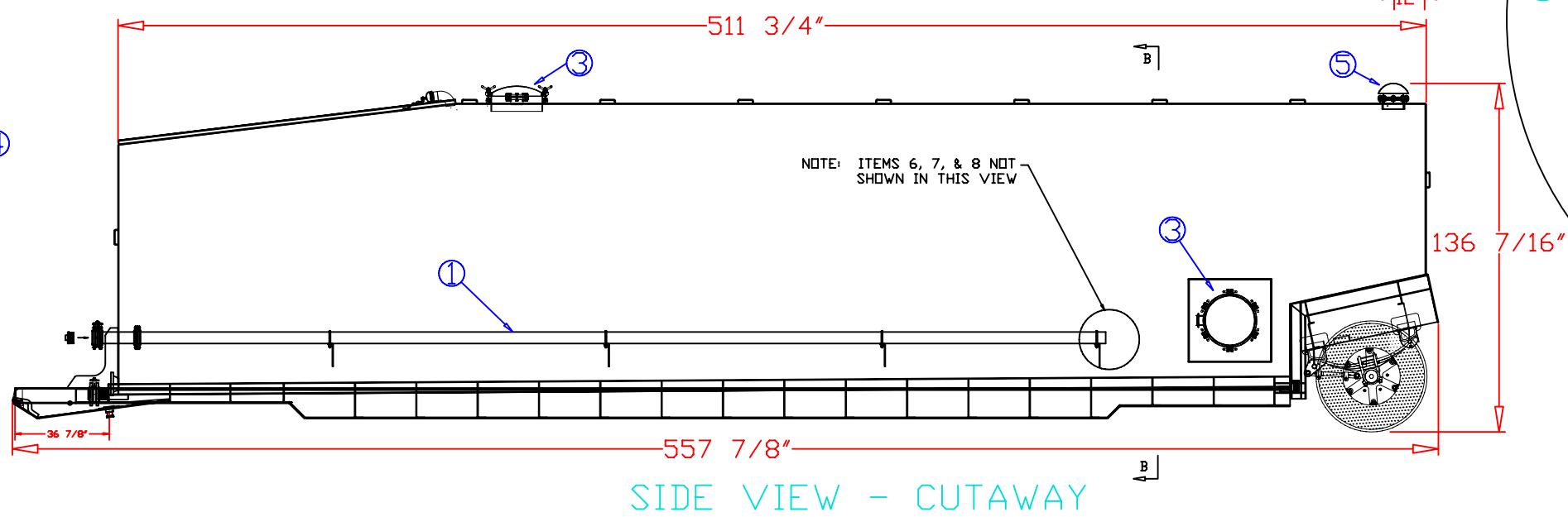
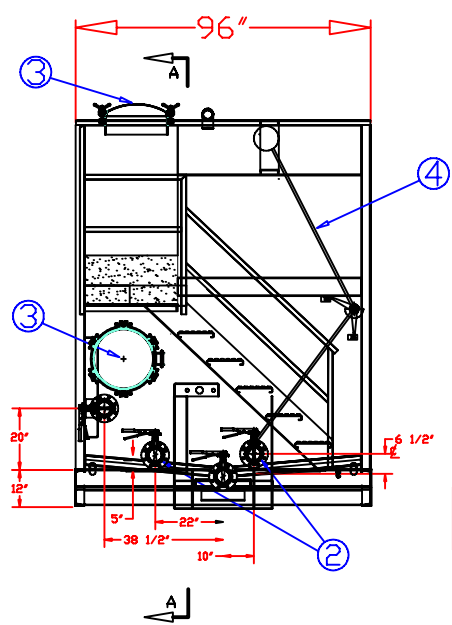
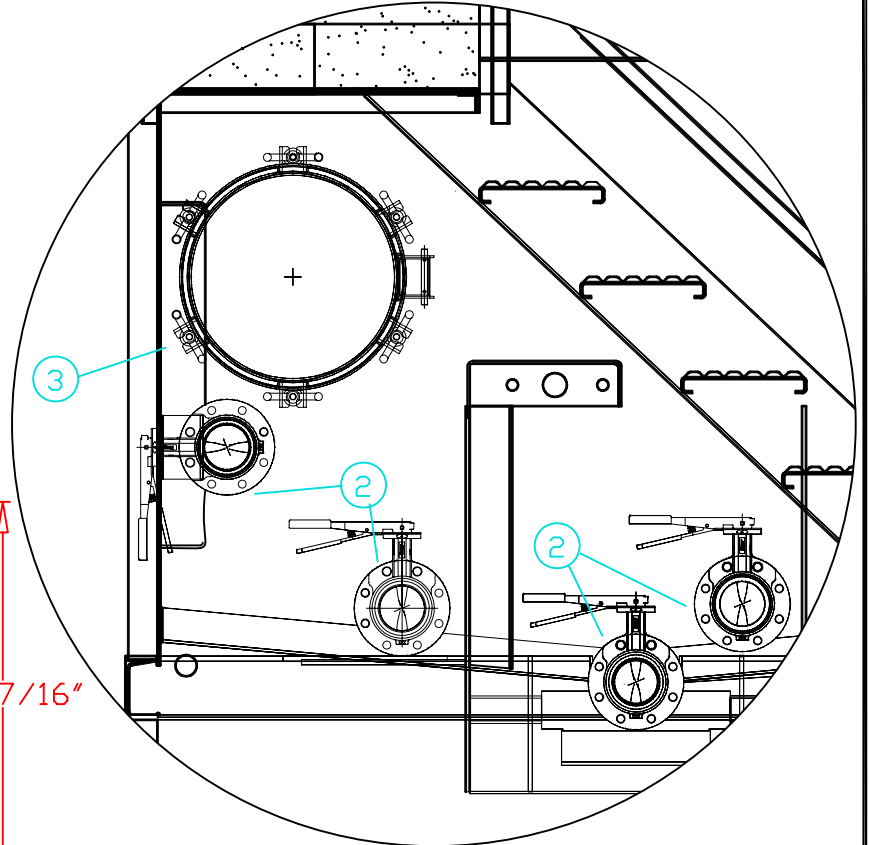
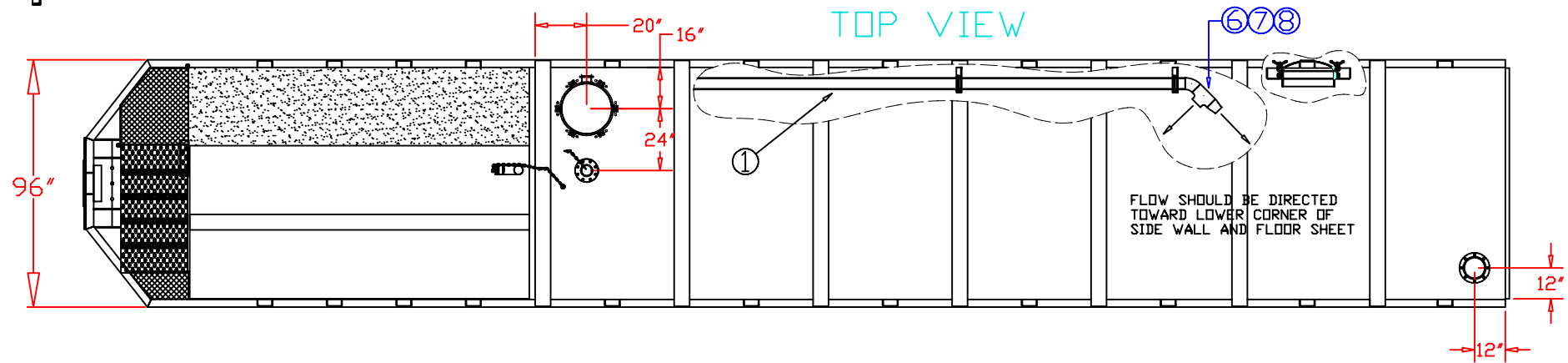

SPECIFICATIONS:

- 1) Tank Capacity: 19,194 gallons (457 BBL)
- 2) Tank Weight: 29,500 lbs. (empty)

NOTES:

- 1. This drawing is a baseline representation for this model of tank. Variations between this drawing and the actual equipment in the field can and do exist, primarily with appurtenance locations, sizes and quantities. Consult your local BakerCorp representative if specific needs exist.
- 2. THIS TANK IS *NOT DESIGNED FOR TRANSPORTING LIQUIDS*. It should be moved only when empty.
- 3. Tanks of this type have an internal lining (coating) on the wetted surfaces.
- 4. This tank is equipped with a pressure/vacuum relief valve set at 1.0 lbs/sq. in. pressure and 0.4 oz/sq.in. vacuum.

The information contained herein is proprietary to BakerCorp and shall not be reproduced or disclosed in whole or in part, or used for any design or manufacture except when user obtains direct written authorization from BakerCorp.

BAKERCORP 3020 OLD RANCH PARKWAY
SEAL BEACH, CA 90740-2751

REV.	DESCRIPTION	DATE	BY
G			
F			
E			
D			
C			
B	FIXED CUTOUTS, LINEWEIGHTS, & TEXT	7/12/05	Z.E.R
A	Revised top view and removed rear hatch	9/7/04	PJB

SCALE: DO NOT SCALE	SIZE B	ORIGINAL DWG. DATE 17JUN02
DRAWN BY: PJB	APPROVED BY:	CAT/CLASS --
TITLE ESP MFG. FIXED AXLE TANK (WITH GEL LINE)		SHEET 1 OF 1
DRAWING NO. S-2-M0002-1-		REV. B