

**PRODUCT DATA SHEET**

April, 2010

**D-KLEEN.WATER 10K**

**GENERAL INFORMATION**

This system is designed for continuous aqueous phase treatment of groundwater or wastewater, and has the ability to remove contaminants to non-detectable levels. The influent stream may be drawn in through the system in either series or parallel flow, and can operate on one vessel only while the other is in backwash mode. BakerCorp can provide a number of service and disposal options for the spent media,

**WEIGHTS AND MEASURES**

»Max. Flowrate:	... Up to 600 gpm in series or 1200 gpm in parallel (application dependent)
»Max. Pressure:	... 100 psi
»Max. Temp:	... 150°F
»Height:	... 10'-6" (overall)
»Width:	... 8'-0" (skid)
»Length:	... 25'-0" (skid)
»Diameter:	... 96" (each vessel)
»Shipping Weight: (empty)	... 40,000 lbs.(equipment – 20,000 lbs; activated carbon – 20,000 lbs)
»Operating Weight:	... 80,000 lbs. (including 40,000 lbs. water)

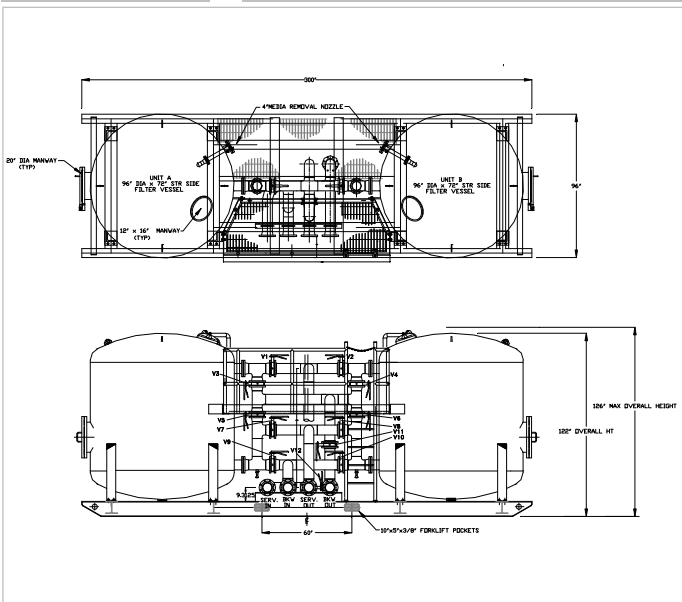

**FILTER MEDIA**

»Types:	... •Activated Carbon •Organoclay •Ion Exchange Resin •Specialty Media
»Volume:	... 320 cu. ft per vessel ( 640 cu. ft. total)
»Weight:	... ~10,000 lbs. each vessel (20,000 lbs. total)

**MISCELLANEOUS DATA**

»Vessel Code:	... ASME Code stamped for 100 psi @ 150°F.
»Service In/Out:	... 6" Flanged connection w/ sch. 40 piping
»Backwash In/Out:	... 6" Flanged connection w/ sch. 40 piping
»Manifold Valves:	... 6" Lever-operated cast iron butterfly
»Media Removal:	... 4" top-mounted nozzle with draw connection at grade
»Internals:	... Lower Underdrain: 6" header/2"x1" drop strainer type constructed of 304 SS & 316SS nozzles Upper Distributor: 6" header/3" open end riser type constructed of 304 SS
»Platform:	... Galvanized grating with perimeter guardrails
»Vessel Interior Access:	... Top manway – 12"x16" elliptical Side manway – 20" round
»Manway Gaskets:	... Neoprene
»Interior Coating:	... Polyamine epoxy coating

**PRESSURE DROP DATA & OPTIONS AVAILABLE**

Contact BakerCorp



**NOTE:**  
Wet activated carbon preferentially removes oxygen from air. In closed or partially closed containers and vessels, oxygen depletion may reach hazardous levels. If workers are to enter a vessel containing carbon, appropriate procedures for potentially low oxygen spaces must be followed, including all federal and state requirements.

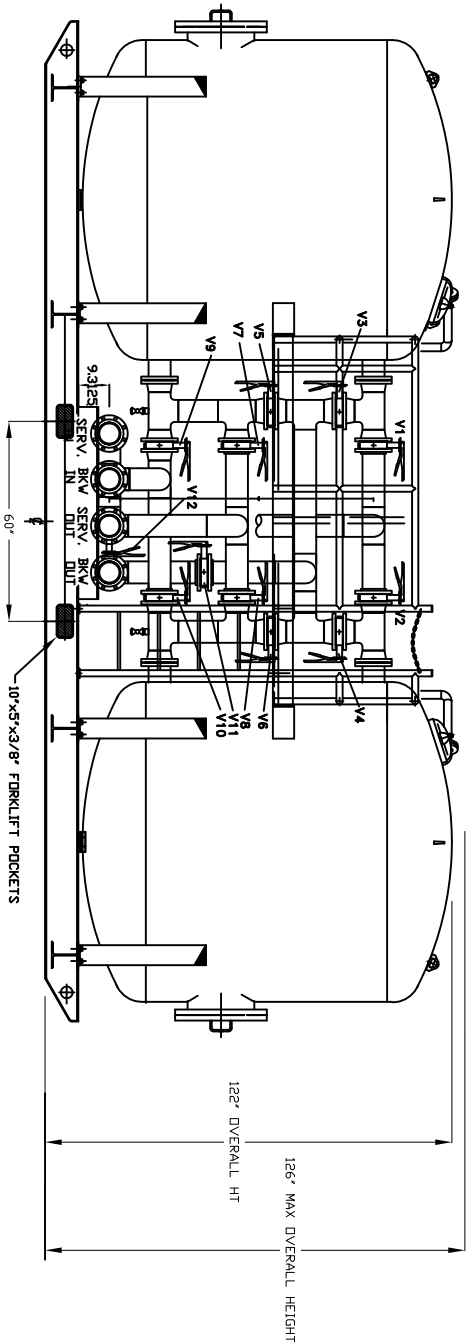
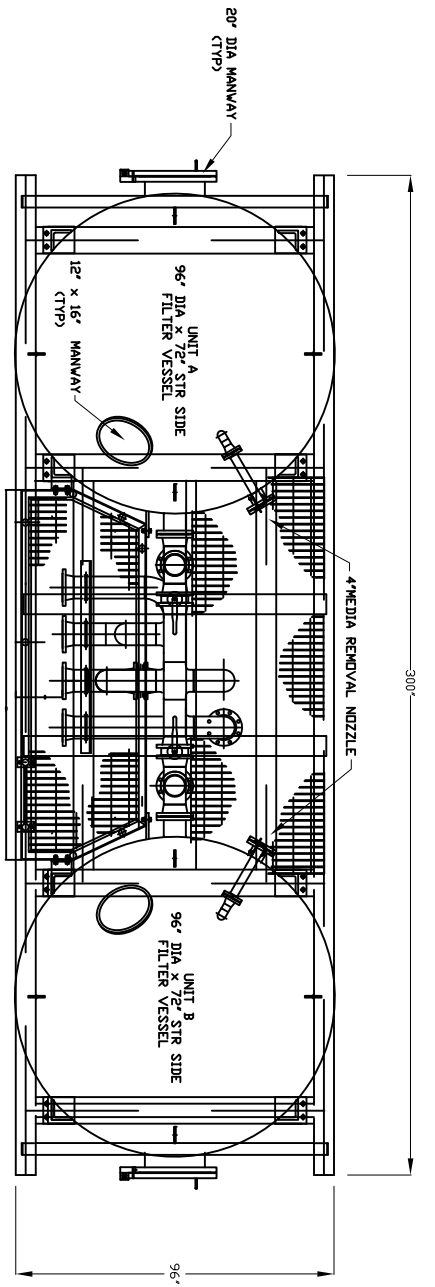

**VALVE OPERATION CHART**

FUNCTION	VALVES OPEN
SERVICE UNIT A	V1, V7
SERVICE UNIT B	V2, V8
PARALLEL SERVICE A&B	V1, V7, V2, V8
SERIES SERVICE A TO B	V1, V5, V4, V8
SERIES SERVICE B TO A	V2, V6, V3, V7
BACKWASH UNIT A	V9, V3, V11
BACKWASH UNIT B	V10, V4, V11
RINSE UNIT A	V1, V5, V11
RINSE UNIT B	V2, V6, V11
SERVICE BYPASS	V12

**GENERAL CONSTRUCTION NOTES**

- VESSEL - ASME CODE STAMPED FOR A WORKING PRESSURE OF 100 PSI AT 150 DEGREES F.
- SURFACE FINISH: VESSEL INTERIOR: PAINT: ONE COAT CARBOLINE PHENOLIC 309, F744 GREY, 25-30 MILS DFT EXTERIOR VESSEL, SKID AND PIPING: PAINT: ONE COAT CARBOLINE CARBOZINC 859, 0300 GREEN, 3-5 MILS DFT ONE COAT CARBOLINE CARBOZINC 859, 0300 GREEN, 3-5 MILS DFT EXTERIOR - PLATFORM, LADDER & HANDRAILS PAINT: ONE COAT CARBOLINE CARBOZINC 134HG, BAKER GREEN, 2-3 MILS DFT ONE COAT CARBOLINE CARBOZINC 134HG, YELLOW, 2-3 MILS DFT
- VESSEL INTERNALS: UNDERDRRAIN COLLECTOR - 6" HEADER/2"x1" DRIP STRAINER TYPE CONSTRUCTED UPPER DISTRIBUTOR - 6" HEADER/3" OPEN END RISER TYPE CONSTRUCTED OF 316SS
- FACE PIPING - 6" SCH 40 WITH 150# RFWN FLANGE TERMINATIONS
- WEIGHTS: EMPTY EQUIPMENT WEIGHT --- 2100 LBS MEDIA, ACTIVATED CARBON (350 CUFT) --- 20000 LBS TOTAL TRANSPORT WEIGHT --- 41000 LBS WATER FILL --- 40000 LBS TOTAL OPERATING WEIGHT --- 81000 LBS

The information contained herein is proprietary to Baker Tanks and shall not be reproduced or disclosed in whole or in part, or used for any design or construction without the express written authorization from Baker Tanks.

**BAKER CORP** 3020 OLD RANCH PARKWAY SEAL BEACH, CA 90740-2751

SCALE: **A** ORIGINAL DWG. DATE: 25/JAN/07

DRAWN BY: P.J.B. APPROVED BY: CAT/CLASS: NA

TITLE: 10K DUPLEX FILTER SKID UNIT SHEET 1 OF 1

DRAWING NO. S-9-M0023-1- REV. 0

REV.	DESCRIPTION	DATE	BY
G			
F			
E			
D			
C			
B			
A			