

## PRODUCT DATA SHEET

January, 2007

## DOUBLE-WALL ABOVEGROUND FUEL STORAGE TANK

### GENERAL INFORMATION

These tanks are designed for diesel or heavier fuels. They are not for gasoline. The tank is a double wall design having one cylindrical tank inside another. There is a small annular area between the two tanks that will contain any leakage from the inner tank, preventing liquid from reaching the environment. The annular area can be monitored for leakage. These tanks are fitted with emergency vents and an overfill alert. Some tanks are fitted with electric dispensing pumps. These tanks are UL-142 and UL-2244 listed.

### WEIGHTS AND MEASURES

» Capacity:	2,500* gal. and 10,000* gal. (*nominal capacity – overfill valve set at 90% cap.)
» Height:	2,500 gal. – 4'-9" 10,000 gal. – 10'-3½"
» Width:	2,500 gal. – 5'-5" 10,000 gal. – 8'-0"
» Length:	2,500 gal. – 18'-0" 10,000 gal. – 31'-3"
» Weight:	2,500 gal. – 7,350 lbs. 10,000 gal. – 18,075 lbs.

### STRUCTURAL DESIGN

» Inner Tank:	ASTM A36 carbon steel 2,500 gal. – 7 ga. shell, 7 ga. head 10,000 gal. – ¼" shell, 5/16" head
» Outer Tank:	ASTM A36 carbon steel 2,500 gal. – 10 ga. shell, 7 ga. head 10,000 gal. – 10 ga. shell, ¼" head
» Pressure and Temperature:	Designed for atmospheric and ambient temperature use.
» Skid Rails:	2500 gal. – Roll-off truck compatible 10,000 gal. – 8" Structural tubing

### FEATURES

» Dispenser:	Fill-Rite model UL305 with 1" inlet and outlet piping. 50 psi max pressure rating. Twelve feet of hose with manual nozzle. Fill-Rite 900 Series positive displacement meter rated up to 40 GPM, and manual reset. Register has three resettable unit wheels and totalizer. Dispenser nozzle shuts off automatically when fuel covers vent hole at the end of the spout.
» Interstitial Cavity:	Inspection port provided so cavity can be checked for leakage; no drain to outside.

### FEATURES – cont.

» Normal Vent:	One removable 2" schedule 40 pipe into primary tank installed on top of tank, fitted with Morrison Bros. Model 749CRBS pressure/vacuum vent. Pressure set at 3" W.C., vacuum set at 8" W.C.
» Emergency Vent Valves:	Primary and secondary vents are Clay & Bailey #368, MNPT- 6" on 2500 gal, 8" on 10,000 gal
» Overfill Alert:	2" Visual Style Krueger Sentry Gauge
» Level Indicator:	One – 2" Morrison clock gauge with audible overfill alarm set at 85% capacity.
» Pump*: * Optional on	Red Jacket (Marley) 1/3 hp 4" submersible model P33R1-T2, Class 1, Group D rated
» Overfill Containment:	Clay & Bailey model 6100-09-1405 5-gal spill containment box w/drain back to tank
» Manway:	2500 gal. – 18" 10,000 gal. – 24"
» Manway Gasket:	UL listed cork
» Ladder:	One OSHA compliant on rear of tank; fold-down top to reduce transportation height.
» Leak Detection:	One 2" secondary monitoring opening (plugged) for "sticking" or "sniffing" the interstitial area. Located on ladder end.
» Electrical:	220 volts required
» Drain:	One 3" with ball valve on front end of tank that dips into sump of inner tank
» Misc. Piping Connections:	Tank fill - 4" schedule 40 threaded pipe Pump - 2" female coupling
» Overfill Prevent Valve:	Clay and Bailey Model F30 with vertical float, allows only 90% tank fill capacity.

### SURFACE DETAILS

» Exterior Coating:	High Gloss Polyurethane
» Interior Liner:	Chemical resistant coating
» Safety Paint:	OSHA yellow

### TESTS/CERTIFICATIONS

» Leak Test:	3 psi air test by manufacturer
» Certifications:	UL142, NFPA 30, NFPA30A, Uniform Fire Code, PEI/RP 200

- (A) 8" PRIMARY EMERGENCY VENT
- (B) 8" SECONDARY EMERGENCY VENT
- (C) 2" VENT
- (D) KRUEGAR VOLUME VISUAL ALERT
- (E) MORRISON BROS. CLOCK GUAGE W/ AUDIBLE ALARM AT 85%
- (F) 5 GALLON SPILL CONTAINMENT W/ DRAIN BACK
- (G) ANULAR MONITOR SPACE
- (H) 1/3 HP SUBMERSIBLE PUMP
- (J) MANWAY
- (K) 3" BALL VALVE
- (L) CLAY & BAILEY F30 VERTICAL FLOAT OVERFILL PROTECTION VALVE

**GENERAL NOTES:**

FABRICATION PER UL-142 & UL-2244  
 LABEL REQ'D. YES  
 DESIGN PRESSURE - ATM.  
 DESIGN TEMPERATURE - AMB.  
 SHOP TEST 3.0 - 5.0 PSI W/SOAP SUDS  
 MATERIAL FOR PRIMARY SHELL SA-36  
**MATERIAL FOR PRIMARY HEADS SA-**  
 MATERIAL FOR SECONDARY SHELL SA-36  
 MATERIAL FOR SECONDARY HEADS SA-36  
 GASKETS VEGETABLE FIBER  
 SAND BLAST INTERIOR: SSPC-SP-6  
 SAND BLAST EXTERIOR SSPC-SP-6  
 PAINT EXTERIOR: CARBOLINE 890

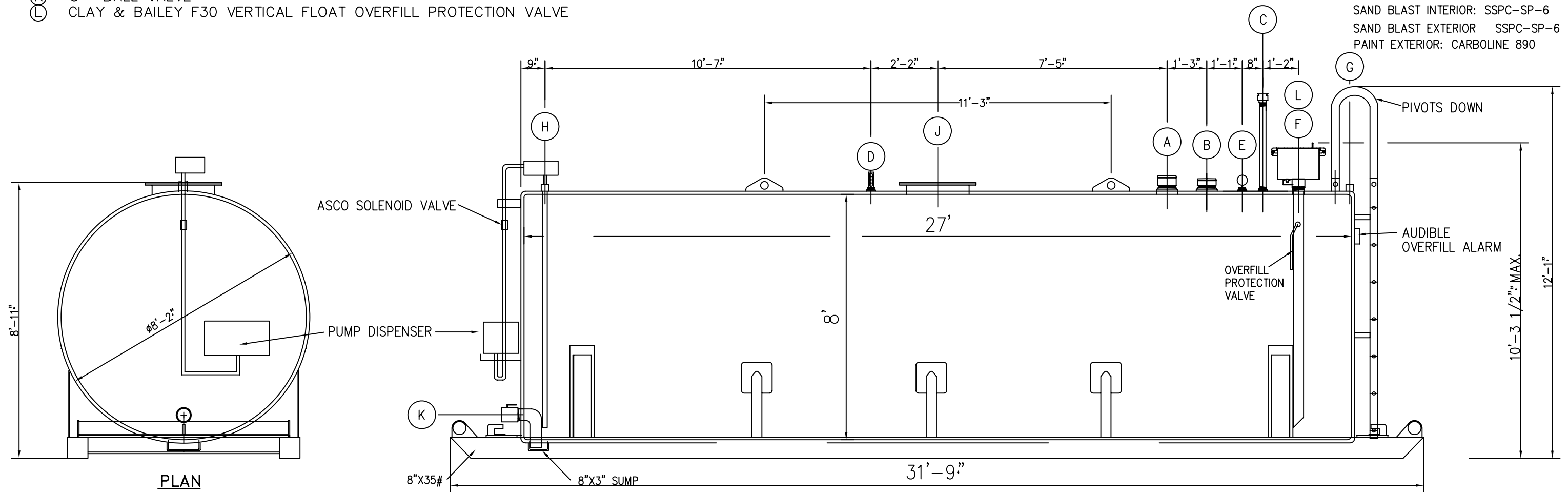

**SPECIFICATIONS:**

- 1) Tank Capacity: 10,000 gallons
- 2) Tank Weight: 18,075 lbs. (empty)

**NOTES:**

- 1. This drawing is a baseline representation for this model of tank. Variations between this drawing and the actual equipment in the field can and do exist, primarily with appurtenance locations, sizes and quantities. Consult your local BakerCorp representative if specific needs exist.
- 2. **THIS TANK IS NOT DESIGNED FOR TRANSPORTING LIQUIDS.** It should be moved only when empty.
- 3. UL-142 and UL-2244 listed.
- 4. Tank is designed for diesel or heavier fuels - not for gasoline.

**ELEVATION**

The information contained herein is proprietary to BakerCorp and shall not be reproduced or disclosed in whole or in part, or used for any design or manufacture except when user obtains direct written authorization from BakerCorp.				3020 OLD RANCH PARKWAY SEAL BEACH, CA 90740-2751		
G				SCALE:	SIZE	ORIGINAL DWG. DATE
F				Do Not Scale	B	09SEP02
E				DRAWN BY:	APPROVED BY:	CAT/CLASS
D				P.J.B.	-	--
C				TITLE		SHEET
B				10,000 GALLON DOUBLE WALL FUEL STORAGE TANK		1 OF 1
A	Added note 1	6/13/03	PJB	DRAWING NO.		REV.
REV.	DESCRIPTION	DATE	BY	S-9-M0007-1-		A