

PRODUCT DATA SHEET

January, 2007

10K SKID TANK (Modern Mfg. – Dragon Products)

GENERAL INFORMATION

This is a skid-mounted tank with standard-spaced roll-off rails. The walls are of the corrugated design.

WEIGHTS AND MEASURES

» Capacity:	238 BBL. (10,000 gallons)
» Height:	8'-1" (grade/top of tank) 9'-8" (grade/top manway)
» Width :	8'-6" (overall)
» Length:	23'-0" (tank only); 26'-5" (overall)
» Weight:	12,700 lbs.

STRUCTURAL DESIGN

» Floor:	¼" thick ASTM A36 carbon steel
» Sides/Ends:	¼" thick corrugated A36 carbon steel
» Top Deck:	¼" thick ASTM A36 carbon steel
» Internal Cross Bracing:	None

FEATURES

» Top Access:	1 - 21" diameter manway on front, driver side; hinged to driver side.
» Front Access:	1 - 21" diameter manway left of centerline, hinged to curbside.
» Side Access:	1 - 21" diameter recessed manway on curbside rear, hinged to rear.
» Manway Seals:	Buna-N

FEATURES – cont.

» Valves:	3-4" 150# threaded flange with butterfly (two on front of tank, one on rear of tank)
» Relief Valve:	Set at 1 psi pressure and 0.4 oz. vac.
» Exterior Ladder:	1 – front end of tank; right of centerline
» Fill Line:	3" sch. 40 top fill with capped MPT extension to front of tank
» Front Drain:	(1) - 4" NPT male w/cap & chain
» Rear Flush:	(1) - 4" NPT male w/cap & chain
» Level Gauge:	None (4" top connection for sticking)
» Wheels:	None, skid mounted
» Overflow:	4" (plugged) near top of front wall
» Skid Rails:	37" inside spacing

SURFACE DETAILS

» Exterior Coating:	High Gloss Polyurethane
» Interior Coating:	Chemical resistant liner

TESTS/CERTIFICATIONS

» Test Performed:	Scheduled QMS inspections
-------------------	---------------------------

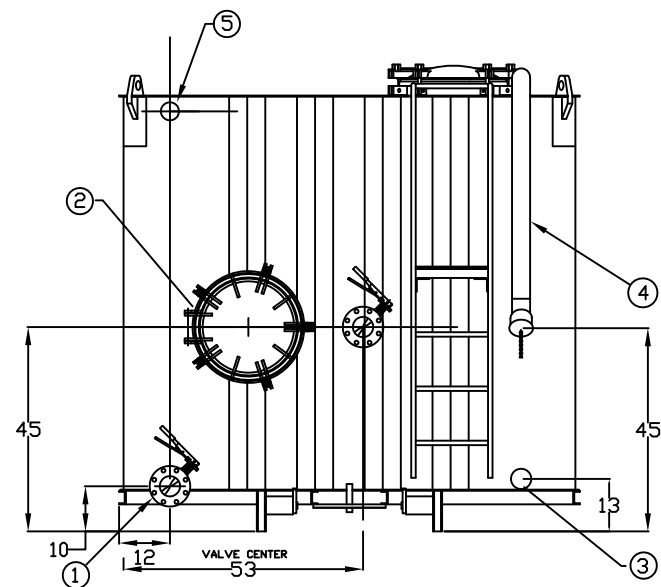

FRONT VIEW

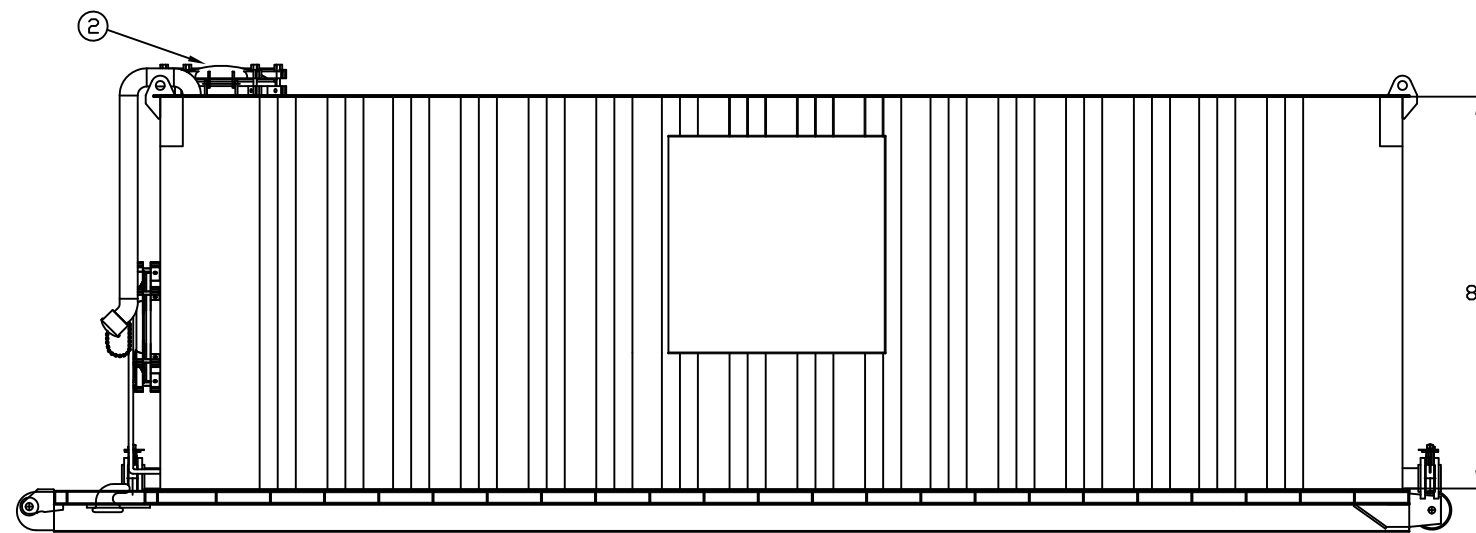

DRIVER'S SIDE ELEVATION

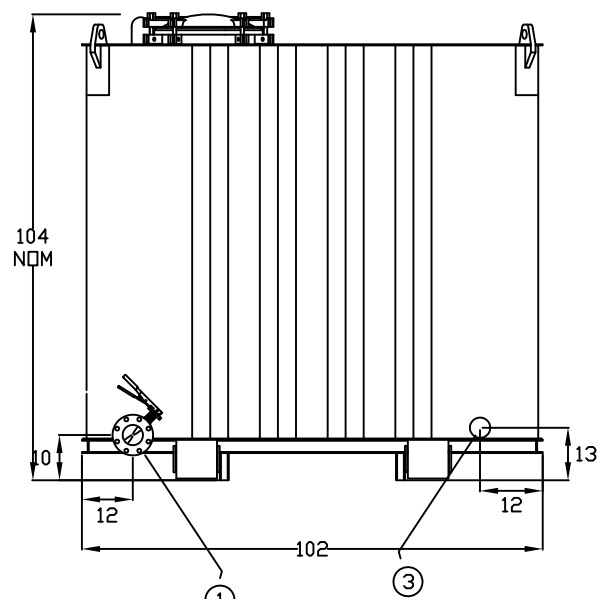

REAR VIEW

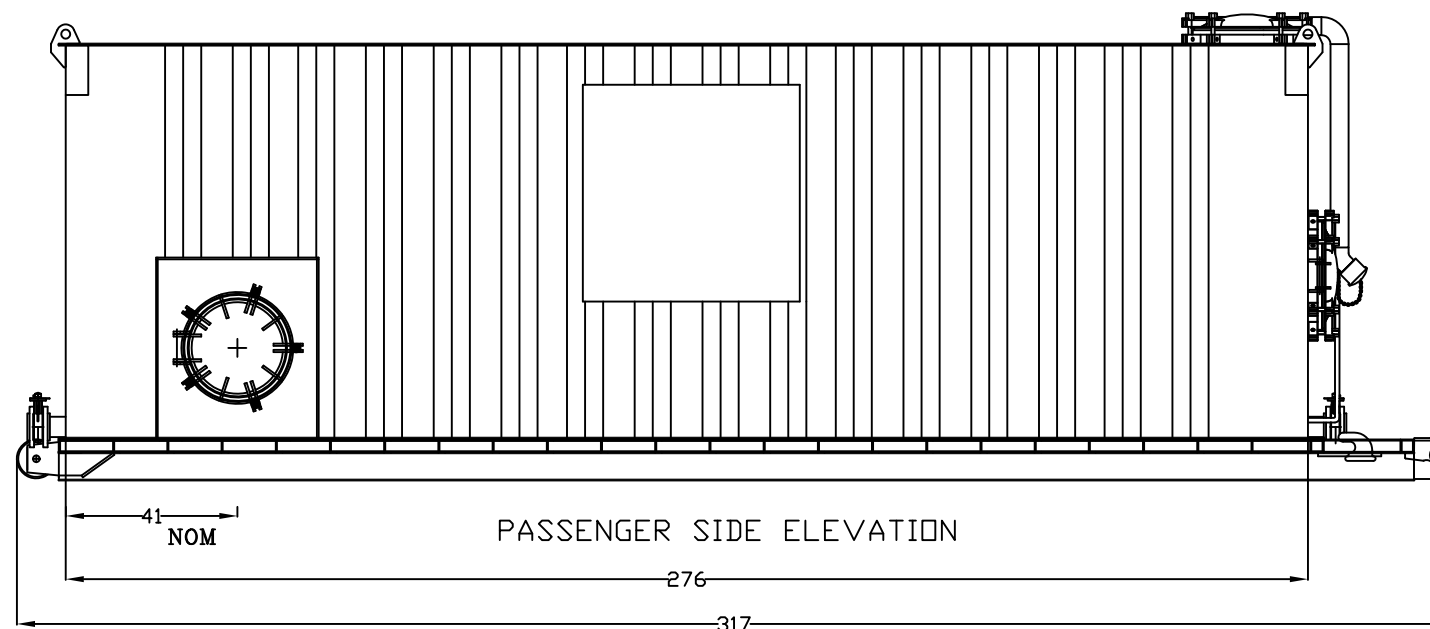

PASSENGER SIDE ELEVATION

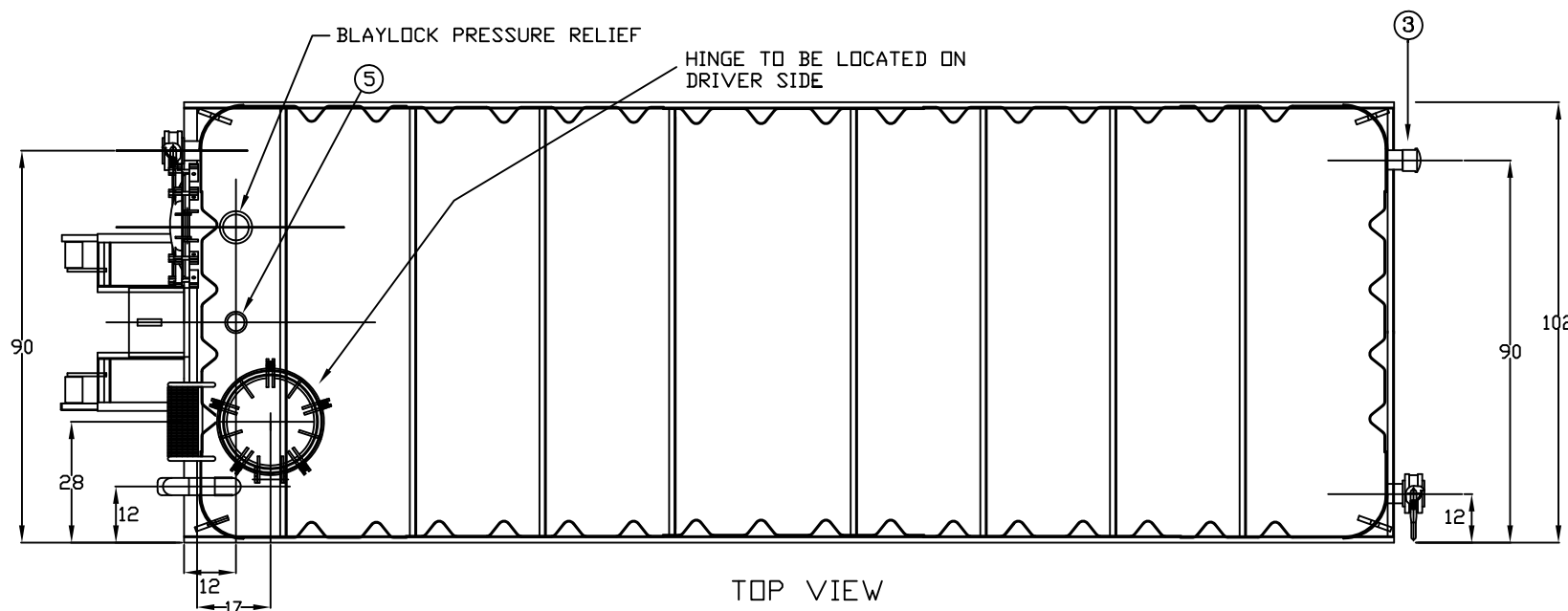

TOP VIEW

ITEM	QTY	DESCRIPTION
1	3	4" 150# threaded flange with cap & chain
2	3	21" manway
3	2	4" NPT male with cap & chain
4	1	3" NPT male with cap & chain (fill line)
5	2	4" half coupling with plug & chain

SPECIFICATIONS:

- 1) Tank Capacity: 10,000 gallons (238 BBL)
- 2) Tank Weight: 12,700 lbs. (empty)



NOTES:

- 1. This drawing is a baseline representation for this model of tank. Variations between this drawing and the actual equipment in the field can and do exist, primarily with appurtenance locations, sizes and quantities. Consult your local BakerCorp representative if specific needs exist.
- 2. THIS TANK IS NOT DESIGNED FOR TRANSPORTING LIQUIDS. It should be moved only when empty.
- 3. Tanks of this type may have an internal lining (coating) on the wetted surfaces.
- 4. This tank is equipped with a pressure/vacuum relief valve set at 1.0 lbs/sq. in. pressure and 0.4 oz/sq.in. vacuum.

The information contained herein is proprietary to BakerCorp and shall not be reproduced or disclosed in whole or in part, or used for any design or manufacture except when user obtains direct written authorization from BakerCorp.

BAKERCORP 3020 OLD RANCH PARKWAY
SEAL BEACH, CA 90740-2751

G				SCALE:	SIZE	ORIGINAL DWG. DATE
F				Do Not Scale	B	31JUL02
E				DRAWN BY:	APPROVED BY:	CAT/CLASS
D				P.J.B.	-	--
C				TITLE		SHEET
B				MODERN MFG. 10K TANK		1 OF 1
A	Corrected volume and weight	5/1/07	PJB	DRAWING NO.		REV.
REV.	DESCRIPTION	DATE	BY	S-9-M0002-1-		A